

Dynamical Analysis of Rotary Tiller : Stress on Chain Tightener

著者	Iwasaki Koichi, Miyabe Yoshiteru, Kashiwagi Sumitaka
journal or publication title	Memoirs of the Faculty of Agriculture, Kagoshima University
volume	29
page range	93-99
URL	http://hdl.handle.net/10232/2926

Dynamical Analysis of Rotary Tiller

—Stress on Chain Tightener—

Koichi IWASAKI, Yoshiteru MIYABE

and Sumitaka KASHIWAGI

(Laboratory of Agricultural Systems Engineering)

Received for Publication September 10, 1992

Introduction

The number of farm tractor in use is around 2 million in 1990 in Japan and the main implement mounted on them is a rotary tiller. And this is due to the fact that the rotary tiller has the benefits to enable turning over and crushing down the soil by one pass method in the process of paddy cultivation. The designing process of the rotary tiller is mainly depended on the experience of designer and the trial & error method except for designing a theory for a rotary blade³⁻⁵⁾ and a rotary shaft^{1,2,6,7)}. The purpose of this study is to establish a designing theory for a rotary tiller which is especially concerned with the power transmission system.

The chain tightener is used for reducing the noise caused by the cultching of the chain and the sprocket, and a vended flat bar is generally used. The tightener is one of the small parts of a rotary tiller but if it should be broken down, the whole machine falls into a serious condition and the tilling work can not be performed. As for the tightener the fatigue strength should be considered because repeated load acts inevitably on that even when the rotary shaft rotates and moreover when the rotary tiller performs tillage work. So the tightener still may be broken in the hard conditioned fields.

In this paper, as the preliminary step to establish the designing theory for the sprocket, chain and tightener system, a geometrical analysis of chain and sprocket motion and the measuring experiments of stress on tightener under a free rotation of a rotary axle were reported.

Geometrical Analysis of Chain-Sprocket and the Tightener Systems

The geometrical relations of the chain-sprocket system depend on the number of sprocket teeth, the distance of two sprocket axles and the number of chain links. To make an analysis of the tightener stress derived from the repeated load and the enlarged deformation, the geometrical relation of tested chain-sprocket system was put under consideration as an example.

The geometrical diagram of the tested sprocket chain system is shown in Fig. 1(a)-(b). The specification of the tested system was as follows.

chain pitch: $p=25.40$ mm

number of chain links: 46

number of sprocket teeth: $n_1=11$, $n_2=17$

radius of pitch circle of the sprocket ($=p/\sin(\pi/n_{1,2})$): $r_1=45.08$ mm, $r_2=69.12$ mm

distance of two sprockets axles: $d=405$ mm

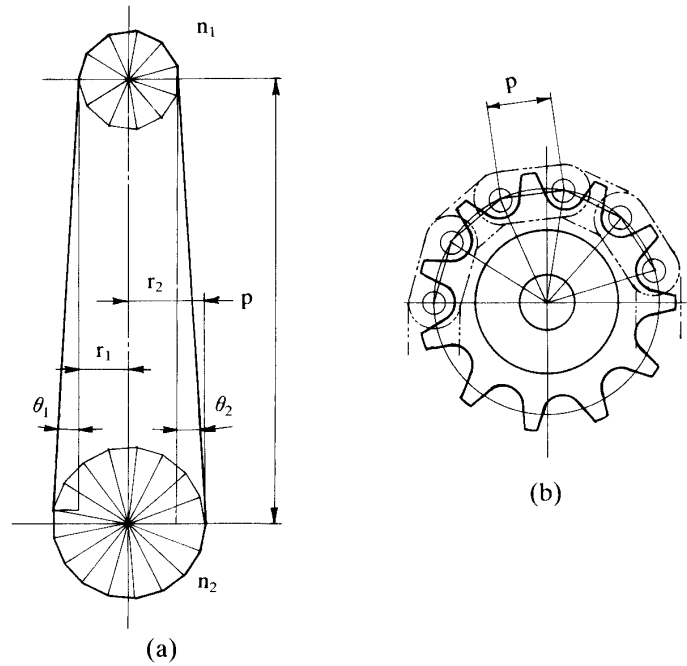

Fig. 1. Geometrical relations of the chain-sprocket system.

As shown in these figures, the chain figures a polygon with two sprockets. The number of chain links clutched with the sprocket is 5 for the small sprocket and 9 for the large sprocket. The minimum total length of the chain L_c (mm) is calculated as,

$$L_c = p(5+9) + (d-p/2)/\cos \theta_1 + (d+p/2)/\cos \theta_2$$

where,

$$\theta_1 = \tan^{-1} \{ (r_2 \cos(\pi/n_2) - r_1) / (d-p/2) \},$$

$$\theta_2 = \tan^{-1} \{ (r_2 - r_1 \cos(\pi/n_1)) / (d+p/2) \}.$$

The calculated chain length L_c is

$$L_c = 25.40 \times 14 + 392.97 + 418.50$$

$$= 1167.07 \text{ (mm)}$$

With 46 link chain, the actual total chain length L_a is

$$L_a = 46(\text{links}) \times 25.40(\text{pitch}) = 1168.4 \text{ (mm)}.$$

Comparing the calculated length L_c and the actual length L_a , we have 1.33 mm difference which is about 0.1% of the minimum length. But as the chain has been forced under a load for a long time, the chain pin and bush must have been worn enough to be elongated. Generally the limit of elongation is 1.5% and in this case the elongated length should be

$$1168.4 \times 0.015 = 17.53 \text{ (mm)}.$$

When the tightener is acting on chain-sprocket system as shown in Fig. 2(a), the chain figures straight line on the opposite side of the tightener, figuring a circular arc on the tightener side. With the enforced 1.5% elongation, the total length of the chain should be 1185.93 mm and the demanded chain length excepting the circular-arc-figured part is calculated as,

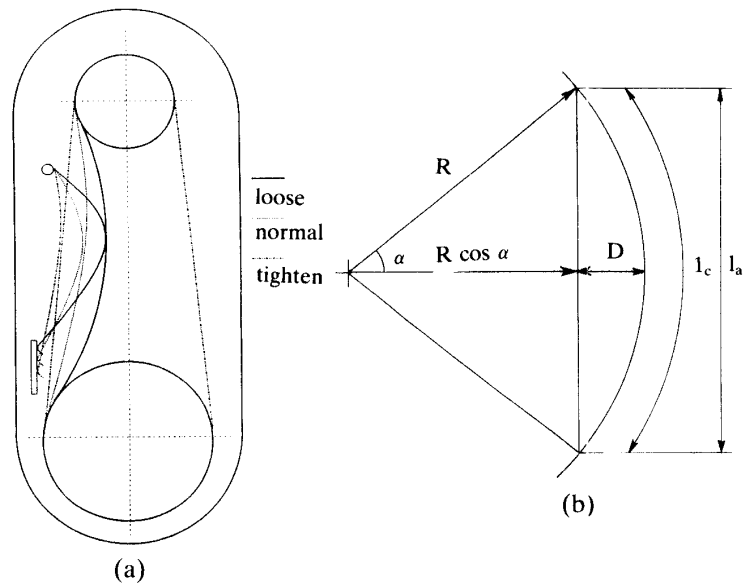

Fig. 2. Deformation of the tightener with chain.

$$1185.93 - 25.40 \times 14 - 418.50 = 411.83 \text{ (mm)}.$$

In this case, the cord length is 392.97 mm.

The relationship of radius R of a circular arc with the length of the arc l_a and the length of the cord l_c is calculated as follows (Fig. 2 (b)),

$$l_c = 2R \sin \alpha$$

$$l_a = 2R \alpha$$

where α is the centric angle of the arc. By substituting above data in these equations, the angle α was calculated to be 0.528 rad and the radius R was 389.99 mm. The maximum distance D from the straight line is

$$D = 389.99 \times \{1 - \cos(0.528)\} = 53.11 \text{ (mm)}.$$

Even without elongation, the demanded length, excepting the circular arc figured part is calculated as,

$$1168.4 - 25.40 \times 14 - 418.50 = 394.3 \text{ (mm)}.$$

In this case, the cord length is 392.97 mm and the centric angle of the arc is 0.142 rad. The radius is 1388.38 mm and the maximum distance from the straight line is 13.97 mm.

Under the hard tilling condition, the straight lined side which is an instantaneously driven side may be a loosened one and the tightener side may be a fastened one. In such a case this distance comes to mean a displacement of the top of the tightener and there should be a huge punching stress on it.

As explained in the above mentioned example, the tightener is only a small part but it has been afflicted by the repeating load and large deformation and furthermore, the chain has been elongated and the deformation must have been enlarged by the machine used for a long time. Accordingly the tightener should be designed with the utmost carefulness taking various aspects into considerations.

Experimental Apparatus and Methods

Measurements of stress acting on a tightener are carried out, using a tractor and a rotary tiller. The specification of the tractor and the rotary tiller is shown in Table 1.

The material of the tested tightener is SK5P, which is an elastically enforced material and generally used for beam spring and so on. The sketched shape and the size of the tested tightener is shown in Fig. 3.

For a measurement of the stress acting on a tightener, three gauges were attached at the center and at the middle point of both sides. The location of strain gauge attachment is also shown in this figure. Before the measurement on the rotary tiller, a calibration using expand-and-compression-machine shown in Fig. 4, was carried out. The calibrated results showed a linear relation between displacement and strain (Fig. 5).

The gauge attached to tightener was installed in chain case, giving tightening force on to the chain as shown in Fig. 6. The rotary tiller was positioned at the height of standard tillage depth. Then the engine speed was kept 1800 rpm in that case rotary shaft was rotated at 155 rpm. In

Table 1. Specification of the tractor and the rotary tiller

Tractor	
Type	MF240
Engine power	48 ps/2250 rpm
Max. torque	17.7 kgm/1250 rpm
Rotary tiller	
Type	SX-1802
Tillage depth	12–14 cm
Tillage width	180 cm
Blade attachment	Flange type
Number of blades	A15L:20, A15R:20
Blade diameter	50 cm
Tillage depth control	Front gage wheel

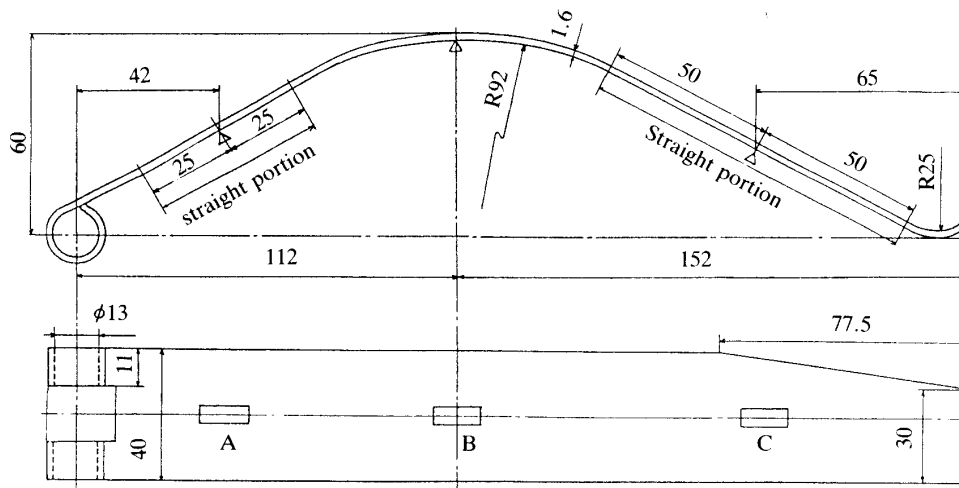

Fig. 3. Sketched shape of the tested tightener and locations of attached gauges.

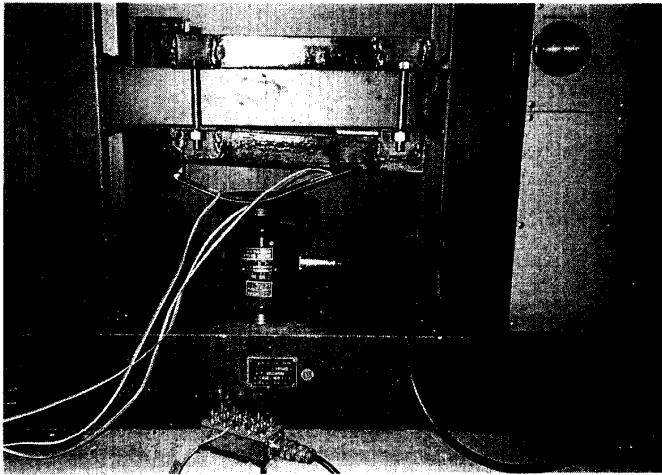

Fig. 4. Calibration using expand and compression machine.



Fig. 6. Installation of the gauge attached tightener.

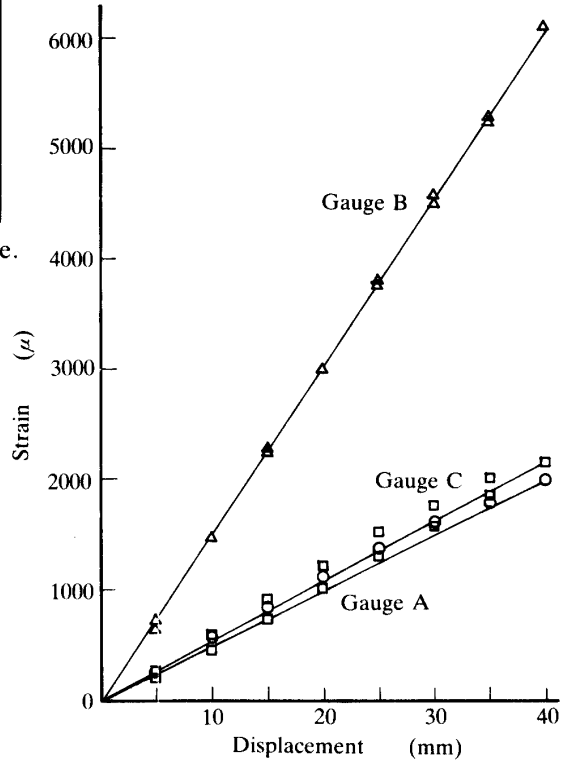

Fig. 5. Displacement and strain on each gauge.

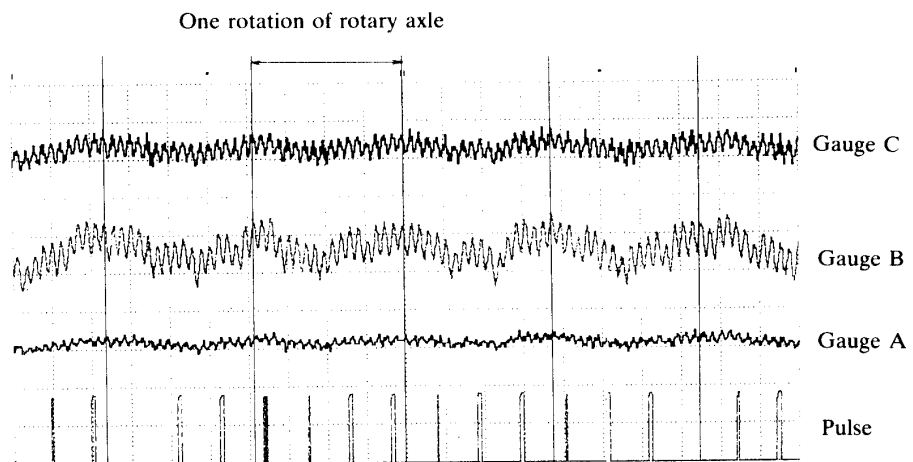

Fig. 7. Example of stress of the tightener at each position.

such a condition the tightener was tightened and loosened by the unbalanced weight of rotary shaft. The stress data were amplified and recorded on the Memory Hi Corder (HIOKI).

Results and Discussion

One example of stress curves of the tightener at the respective three positions is shown in Fig. 7. The curve (a) to (c) is the stress at the point A to C respectively and the pulse represents one rotation of the power-intake connection shaft. As shown in this figure, the stress at the center (position B) showed the largest and that at the end side (position C) showed smaller stress and the rolled side (position A) showed the smallest. The measured three curves seemed to be composed of with two different frequency-band curves. The one may be originated from sprocket and chain clutching and the other occasioned by the mass unbalance of the rotary shaft. Various trends seemed to be common through these three curves and for the designing of the tightener the large stress point is the most important, therefore discussions of the experiment are focused at the center (position B) of the tightener.

1. The magnitude of stress

When the tightener was insatalled on to the chain-sprocket system, the strain was 3400μ and the stress was 70.9 kg/mm^2 . The average magnitude of the stress added to this initial stress by the rotation which resulting in the clutching of the sprocket and the chain and the unbalance load on the chain by the rotary shaft was 7.9 kg/mm^2 .

2. Frequency analysis of the measured curve

(1) Influence of sprocket chain system

The frequency of the short cycled curve seemed to be around 45 Hz and it was related to rotational speed of sprocket shaft. In this case, the number of teeth of larger sprocket was 17 and when the sprocket shaft rotates at 155 rpm, the number of clutching of the chain and the sprocket is 44.2 times per second and it is obviously known that this cyclic phenomenon causes the high frequency vibration.

(2) Influence of rotary shaft mass-unbalance

The frequency-in-low seemed to be around 2.5 Hz and it was related to the rotational speed of the rotary shaft. In this case, the rotational speed of the rotary shaft was 155 rpm and it means 2.6 Hz and it is obviously known that this cyclic phenomenon causes the low frequency vibration.

The rotary shaft is designed to perform mass balance in rotational direction and also in horizontal direction for the purpose of bringing about smooth tillage and smooth surface of the tilled soil. But even in that case, perfectly balanced distribution of the rotary blade is an ideal one and at the some time there should be a small unbalance in any rotary shaft. So the sprocket and chain system is affected by this unbalance of the roatry shaft, and the tension and compression movement and extended influence on tightener are brought forth.

With the executed geometrical analysis and the stress measurement experiments, the tightener should bear against repeating load and large defomation, which are to be caused by the elongation of the chain and the mass unbalance of the rotary shaft. Further research regarding the influence of the tillage resistance against the various soil and tilling conditions is expected.

Summary

As the first step to establish a designing theory for a rotary tiller especially for the transmission system, the chain-sprocket and the tightener system were analyzed geometrically and the stress-measurement of the tightener was carried out. The obtained results are as follows.

(1) With the geometrical analyses of the chain-sprocket system, and of the chain length calculated by chain pitch times the number of chain links was about 0.1% longer than the minimum length calculated geometrically with polygon figure. Even in this case, the displacement of the tightener top was calculated to be 13.97 mm.

(2) With the wearing of chain parts, the total length of the chain may be elongated and at 1.5% elongation, the displacement of the top of the tightener should be 53.11 mm. Such a large displacement means quite a hard stress condition for the tightener.

(3) By the measurement of the stress on the tightener, the magnitude of the stress at the top of the tightener was 70.9 kg/mm^2 at the installation to the chain-sprocket system, and the additional stress 7.9 kg/mm^2 acted on it with free rotation of the rotary shaft.

(4) The measured stress curve seemed to be composed of the two different frequency curves. The short cycled curve was around 45 Hz and this value was very close to the number of clutching per seconds in case of the chain and the sprocket. The large cycled curve was around 2.5 Hz and this value was very close to the rotational speed of the rotary shaft. This means that the stress on the tightener is influenced both by the clutching of the chain and the sprocket and by the mass unbalance of the rotary shaft.

References

- 1) Chen, P., Sakai, J. and Noguchi, R.: Studies on Optimum Design Theories of a Rotary Shaft and Expert CAD System (Part 3). *J. Soc. Agr. Machinery, Japan*, **53**(2), 53–61 (1991) (in Japanese with English Summary)
- 2) Chen, P., Sakai, J. and Noguchi, R. : Studies on Optimum Design Theories of a Rotary Shaft and Expert CAD System (Part 4). *J. Soc. Agr. Machinery, Japan*, **53**(3), 35–45 (1991) (in Japanese with English Summary)
- 3) Lam, V. H. and Sakai, J.: Studies on the Cultivating Characteristics of the Knife-Edged Curve of Japanese Rotary Blades. *J. Soc. Agr. Machinery, Japan*, **44**(4), 611–615 (1983) (in Japanese with English Summary)
- 4) Sakai, J., Shibata, Y. and Taguchi, T. : Design Theory of Edge-Curves for Rotary Blades of Tractors. *J. Soc. Agr. Machinery, Japan*, **38**(2), 183–190 (1976) (in Japanese with English Summary)
- 5) Sakai, J. and Shibata, Y. : Design Theories on Scoop-Surfaces of Rotary Blades for Tractors. *J. Soc. Agr. Machinery, Japan*, **39**(1), 11–20 (1977) (in Japanese with English Summary)
- 6) Sakai, J. and Shibata, Y.: Design Theory of Rotary Blades Arrangement for Tractors. *J. Soc. Agr. Machinery, Japan*, **40**(1), 29–40 (1978) (in Japanese with English Summary)
- 7) Sakai, J., Chen, P. and Yamanaka, S.: Studies on Optimum Design Theories of a Rotary Shaft and Expert CAD System (Part 2). *J. Soc. Agr. Machinery, Japan*, **52**(4), 45–52 (1990) (in Japanese with English Summary)