

Model Experiments on Double Rigged Shrimp Trawl Gear : Physical Characteristics of Balloon Net

著者	IMAI Takehiko, RIVADENEYRA MARIN Hector
journal or publication title	鹿児島大学水産学部紀要=Memoirs of Faculty of Fisheries Kagoshima University
volume	27
number	1
page range	139-146
別言語のタイトル	2統曳エビトロール網の模型実験
URL	http://hdl.handle.net/10232/13121

Model Experiments on Double Rigged Shrimp Trawl Gear

Physical Characteristics of Balloon Net

Takehiko IMAI*¹ and Hector RIVADENEYRA MARIN*²

Abstract

This study was carried out for the purpose of determining some physical characteristics of scale model of the balloon type double rigged shrimp trawl gear in the experimental tank. The net model was constructed in accordance with Dr. Tauti's similarity-law of fishing gear.

The measurements were carried out both on the shapes and on the resistances in seven stages of towing velocity (V). For the convenience of discussions, the experimental values were converted into full scale values.

Results were obtained as in the following:

1) Under the consideration of the physical characteristics of the gear efficiency, we have some parameters obtained as net mouth height (H), net mouth area (A), and wing tip distance (W).

The above parameters are represented as in the following:

$$H=2.7 V^{-0.60}$$

$$A=0.016 V^{-0.52}$$

$$W=2 V+10.6$$

In the discussions of shrimp trawl gear efficiency, it is better for us to use the sweep area parameter of the gear (S_A), than to use the filtering volume (F_V).

The sweep area is represented as in the following:

$$S_A=14.5 V^{-1.4}$$

2) Concerning with the hydraulic resistance of the gear, the results were obtained as in the following:

$$R_T=360 V^{1.74}$$

$$R_N=312 V^{1.71}$$

$$R_{OB}=44 V^{2.0}$$

Introduction

The double rig shrimp trawl gear is made of trawl net and two flat otter boards connected directly by head rope and ground rope ends at the wing tip. Based on the construction of the net panels, there are three kinds of shrimp trawl net, flat net, balloon net, and semiballoon net.

*¹ 鹿児島大学水産学部漁具学研究室 (Laboratory of Fishing Gear, Faculty of Fisheries, Kagoshima University, Japan)

*² Instituto de Ciencias y Tecnologías del Mar, Veracruz, Mexico. (Institute of Sciences and Marine Technologies, Veracruz, Mexico)

This experimental model was tested in a balloon type of shrimp trawl gear in an experimental circular tank.

In making a reduced scale model we adopted simple construction as the original model. Based on Tauti's comparative methods this trawl was tested as a scale model.

The model net was made in accordance with Tauti's similarity law, however as it was not possible to get the same net materials used in the full scale, as far as the net materials are concerned, we did not comply with Tauti's law. (See Fig. 1, and Fig. 2)

In the deduction of our scale model the following parameters were considered:

the scale ratio: $\lambda'/\lambda''=1/20$

the ratio of mesh and diameter of twine: $\frac{D'}{D''} = \frac{L'}{L''} = K = 0.190$

Where:

- λ = scale
- D = diameter of twine
- L = mesh size
- K = constant
- ' = scale model
- '' = full model

The netting material used in the full model was polyethylene while, in the construction of the scale model as material nylon was used, in case of the otter boards, which were plastic.

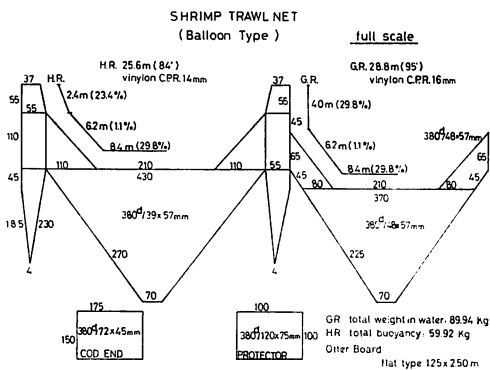

Fig. 1. Plan of the original net.

- H. R.: head rope
- C. P. R.: compound rope
- G. R.: ground rope
- m: meter d: denier

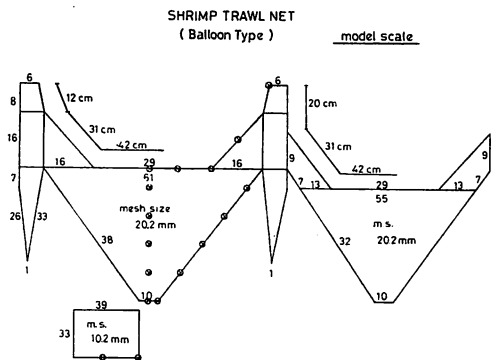

Fig. 2. Plan of the experimental net.

- m. s.: mesh size
- ⊗: measuring point

Methods

This experiment was made to determine the two items; the first to determ-

ine the total resistance and net shapes of the fishing gear, and the second to determine the net resistance at the respective towing velocity. The equipments used in the measurements in the first part of this experiment are shown in Fig. 3, and those in the second part are shown in Fig. 4.

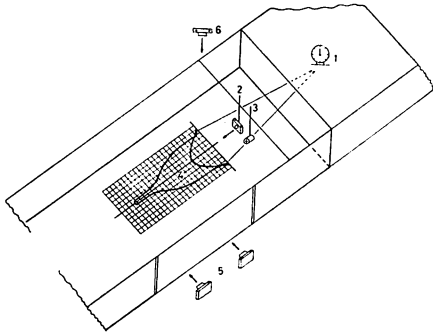

Fig. 3. Schematic drawing on experimental equipment in circular tank, at the primary experiment.

- 1 : spring balance
- 2 : underwater camera
- 3 : current meter
- 4 : trawl gear model
- 5 : cameras (side view)
- 6 : camera (plane view)

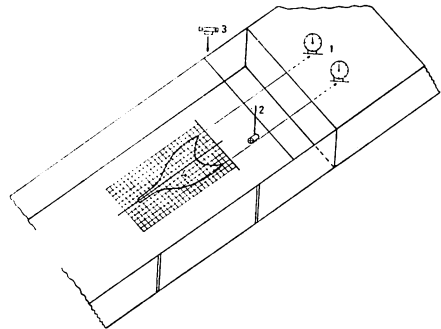

Fig. 4. Schematic drawing on experimental equipment in circular tank, at the secondary experiment.

- 1 : spring balances
- 2 : current meter
- 3 : camera (plane view)
- 4 : trawl net

In this experiment, seven towing velocities were examined, every one of which was, calculated in accordance with the Tauti's similarity law, on 0.5, 1.0, 1.5, 2.0, 2.5, 3.0, and 3.5 knot. The measurement of the flow speed in the experimental circular tank was transformed by electrical pulsation, using Toho Dentan CM 10S current meter. Each flow velocity was adjusted by an electrical motor, driving paddle wheels in the circular tank. By reading each measuring point on the XYZ coordinate system, different net shapes were ascertained at each flow velocity in the tank. This net was also checked in the three different views (front, side, and plane) by photography.

The measurement of the total resistance at each flow velocity was obtained directly using a spring balance with two kilogram capacities. Net resistance was also measured in a different way, using two spring balances, with one attached at each wing tip. In case of the later experiment the value was adjusted, as much as possible, to the former values obtained at the wing tip distance and at the flow speed.

Results and Discussion

It was possible to draw all the net shapes with the knowledge of the coordinate values of X , Y , Z , for each point measured. The plane views were drawn,

using the plotting points obtained from the values of X, Y . Side views from the values of Y, Z , and front views from X, Z .

Now, all empirical values are to be converted into full scale for convenience of discussions. As showed in Fig. 5 in the relationship between net mouth height and towing velocity, the points showed empirical value and the curve showed experimental equation. It was assumed that the relationship showed an exponential function, and following equation was obtained by exponential regression.

$$H = 2.7 V^{-0.60} \quad (1)$$

Where:

H = height of net mouth (m)

V = towing velocity (m/s)

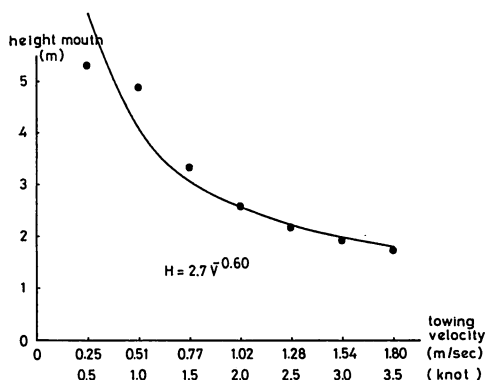

Fig. 5. Relationship between net mouth height (H) and towing velocity (V).

The net mouth height decreased quickly as the towing velocity increased. When the usual towing velocity was about 2.5 to 3.0 knot, the net mouth height was shown 2.3–2.0 m. It was assumed that this value for net mouth height was to be remaining constant, with the further increases in the towing velocity, because the net mouth height was to be maintained by otter board.

The relationship between both the wing tip distance and the towing velocity was a linear relation, as shown in Fig. 6. The value of the wing tip distance increased with the velocity up to 3.0 knot, but tended to decrease at 3.5 knot which was obtainable maximum flow velocity in the experimental circular tank. In this experiment, it was not possible for us to observe clearly the characteristics of the trawl gear at high towing velocities.

Based on the linear regression, the wing tip distance was determined as given below:

$$W = 2 V + 10.56 \quad (2)$$

Where:

W = wing tip distance (m)

V = towing velocity (m/s)

Fig. 7 shows the relationship between sweep area in the trawl gear (S_A) and towing velocity. It was possible to obtain the sweep area per unit time by multiplying the wing tip distance and towing velocity. Thus,

$$S_A = W \cdot V$$

But in case of Fig. 7 it was assumed that the relationship had a linear function and the equation was obtained by linear regression.

$$S_A = 14.52 V - 1.36 \tag{3}$$

Where:

S_A = sweep area of the gear (m^2/s)

In the double rig shrimp trawl otter boards, wooden flat lateral type was usually used, the boards had a lower lift per drag value. This lift-drag ratio determined the fluid dynamical efficiency of the otter board.

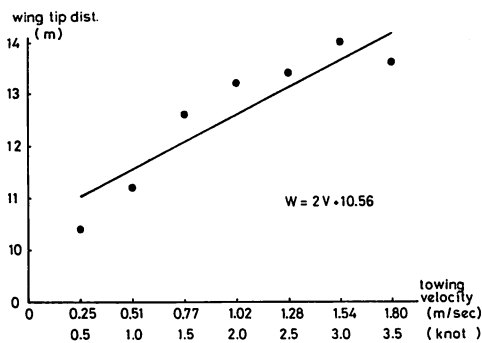

Fig. 6. Relationship between wing tip distance (W) and towing velocity (V).

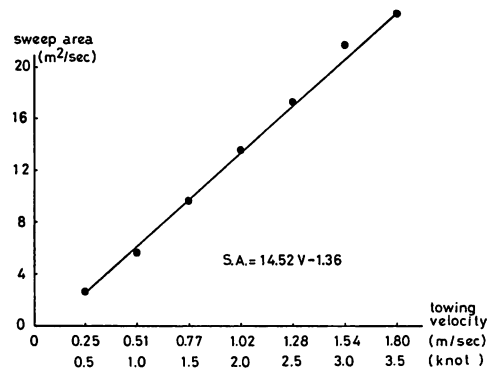

Fig. 7. Relationship between sweep area (S_A) per unit time and towing velocity (V).

When we used wider otter boards commonly used on shrimp trawler was expected greater sweep area. But in this experiment the effect of the otter board was eliminated in the calculations, because it was impossible to determine exactly the point of contact between otter board and the floor of the tank.

The net mouth area was measured, using a planimeter in the frontal view plan for each velocity. The relationship between net mouth area and towing velocity was shown in Fig. 8. When we calculate exponential regression about the values obtained with the exception of the value of 0.5 knot, the empirical equation was represented as in the following:

$$A = 0.016 V^{-0.52} \tag{4}$$

Where:

$$A = \text{area of the net mouth (m}^2\text{)}$$

In the discussion about the efficiency of general trawl gear, it is necessary to denote that the high efficiency of the net is related to the filtering volume per unit time. From the equation (4) it is possible for us to denote that:

$$F_v = A \cdot V \approx K \cdot V^{0.5} \quad (5)$$

Where:

$$F_v = \text{filtering volume (m}^3\text{/s)}$$

$$K = \text{constant (in this case 0.016)}$$

On the other hand, calculation carried out in the same method, about the value obtained, was represented by:

$$F_v = 0.016 V^{0.68} \quad (6)$$

As shown in Fig. 9, continuous curve was obtained by equation (6), and the dotted curve was obtained by equation (5).

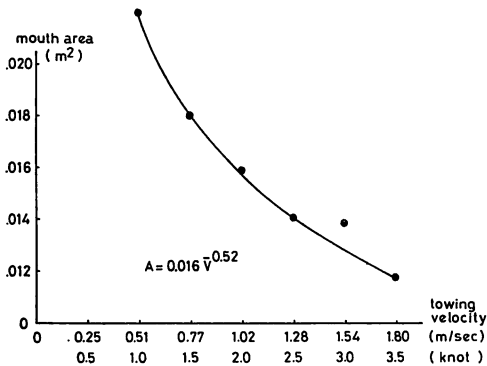

Fig. 8. Relationship between net mouth area (A) and towing velocity (V).

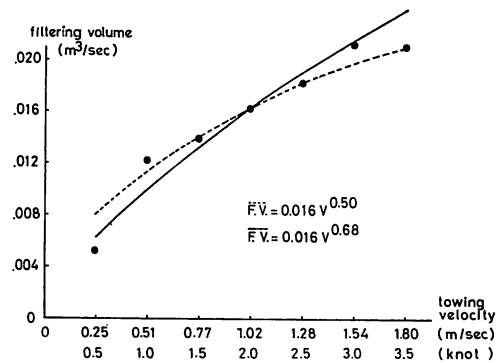

Fig. 9. Relationship between filtering volume (F_v) per unit time and towing velocity (V). Continuous curve was obtained by equation (6), and the dotted curve was obtained by equation (5).

It was assumed that in both the equations index value was to be equal, but we obtained a little difference in the values. We supposed that the reason was due to the empirical error of net mouth area measured.

In case of the shrimp trawl, basing the discussion about the efficiency of catching upon the sweep area, because was considered better, for the sweep area is more important than filtering volume, as the ecological medium of the shrimps is apt to be confined on to bottom, accordingly we considered that it was important to keep between the two wings the distance broader than in case of the net mouth area wider.

In the first part of this experiment, the relationship between the total trawl

resistance and towing velocity was determined. In the second part, the objective was to obtain the trawl resistance of our net, and then to obtain the otter board resistance, presuming that the resistance of the bridle was negligible. Therefore,

$$R_{OB} = R_T - R_N$$

Where:

$$R_T = \text{total gear resistance (kg)}$$

$$R_N = \text{trawl net resistance (kg)}$$

$$R_{OB} = \text{otter board resistance (kg)}$$

Fig. 10 denotes the relationship between total resistance and towing velocity, net resistance and (V), otter board resistance and (V). The empirical equations obtained are as in the following:

$$R_T = 360 V^{1.74} \tag{7}$$

$$R_N = 312 V^{1.71} \tag{8}$$

$$R_{OB} = 44 V^{2.0} \tag{9}$$

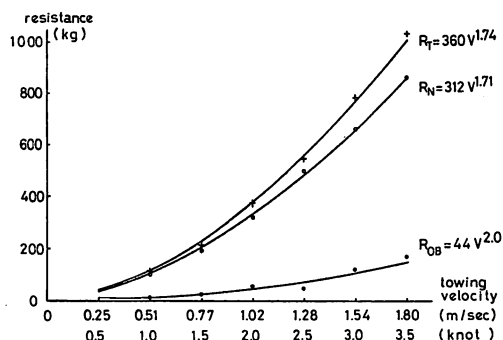

Fig. 10. Relationship between total resistance (R_T) and towing velocity (V), net resistance (R_N) and (V), otter board resistance (R_{OB}) and (V).

The equation of net resistance was obtained by exponential function of towing velocity, and the index value obtained was 1.71. This value was similar to that obtained by Higo (1971)¹⁾ on the model of a stern trawl net, which was composed of four panels of netting. The index values obtained were 1.66-1.99 in circular tank experiments, which depended on the wing tip distance, Nomura et al. (1953)²⁾ and Honda (1958)³⁾ conducted model experiments on traditional two panel trawls, and obtained the index value of 1.35-1.40 and 1.30-1.76 respectively. Then the shrimp trawl net was assumed to have characteristics of water resistance similar to those of the four panel general trawl net.

Otter board resistance was denoted by equation (9) and the index value was obtained similarly by flat plate in the stream. Now, compared with the ratio between total resistance and otter board resistance in percentage, the value was obtained between 10.3-14.2%.

In this experiment we planned to set the attack angle of the otter board at 30°, but the obtained result measured from photographic analysis was shown to be between 30.1-33.6°. Other experiments conducted at sea by Koyama (1965)⁴⁾ resulted in the ratio 15.2-29.8%. In the case of circular tank experiments it was difficult to obtain frictional resistance of otter board, so this resistance was neglected. It was easy to understand the value of otter board resistance was to be increase to Koyama's result, when it was under towing conditions at sea.

If we adopted hydrofoil otter boards like Süberkrüb's type⁵⁾ it was possible to decrease the otter board resistance. Then it was assumed that it was possible to increase the size of trawl or to increase the towing velocity. Consequently it was supposed possible to obtain greater sweep area of the gear, though it was assumed necessary to make further discussions on the operational and equipmental problems.

Acknowledgments

Respectfully to Dr. Nobio Higo for all the facilities granted in the performance of this study. To Mr. Shigeru Fuwa, Mr. Shizuo Tabata, Students of our Laboratory of Fishing Gear, and Mr. Jaime Orosa Teyer for their grand help received during the development of this experiment.

References

- 1) Nobio HIGO (1971): Fundamental Studies on the Fishing Efficiencies of Trawling Nets., *Mem. Fac. Fish., Kagoshima Univ.*, 20(2), 1-137.
- 2) Masatsune NOMURA and Tatsuo YASUI (1953): Model Experiments on Trawl Nets of Various Types., *Bull. Jap. Soc. Sci. Fish.*, 18, 727-733.
- 3) Katsuji HONDA (1958): A Model Experiment for Trawl Nets., *Bull. Jap. Soc. Sci. Fish.*, 23, 608-611.
- 4) Takeo KOYAMA (1965): On the Results of Field Trial with Various Big Sized Otter Trawls., *Bull. Tokai Reg. Fish. Res. Lab.*, 43, 13-71.
- 5) SHARFE, J. (1959): Experiments to Decrease the Towing Resistance of Trawl Gear., "Modern Fishing Gear of the World", Fishing News (Books) Ltd., London, England, 245-247.