

# Visualization of Amount of Nursing Care Provided and Accessibility to Nursing Care Using DPC in Acute-Phase Inpatient Hospital Care

Matsumoto Chiharu <sup>1,2</sup>; Uto Yumiko <sup>3</sup>; Muranaga Fuminori <sup>3</sup>; Kumamoto Ichiro <sup>3</sup>

<sup>1</sup> Kagoshima University Graduate School of Medical and Dental Science, 8-35-1, Sakuragaoka, Kagoshima, Kagoshima 890-8520, Japan. [matsu-c@nursing.osakafu-u.ac.jp](mailto:matsu-c@nursing.osakafu-u.ac.jp)

<sup>2</sup> Department of Nursing, Clinical Health Nursing, Osaka Prefecture University, 3-7-30, Habikino, Habikino, Osaka 583-8555, Japan.

<sup>3</sup> Department of Medical Information Sciences, Graduate School of Medicine and Dental Sciences, Kagoshima University, 8-35-1, Sakuragaoka, Kagoshima, Kagoshima 890-8520, Japan.

**Keywords:** Diagnosis Procedure Combination (DPC), Hospital Information System, Nursing Management, Nursing care, Patients' characteristics

## Summary

**Objective:** The purpose of this study was to improve accessibility to nursing care by clarifying the relationship between patient characteristics and the amount of nursing care for the Diagnosis Procedure Combination system (DPC). **Method:** The subjects included 528 lung cancer patients; 170 gastric cancer patients; and 91 colon cancer patients, who were hospitalized from July 1, 2008, to March 31, 2010, at a university hospital. The patients were categorized into groups according to factors that could affect the amount of nursing care. Next, the relationship between the patient characteristics and the amount of nursing care was analyzed. Then the results from this study were used to classify patient characteristics according to the patient type and the amount nursing care required. **Results:** The patient characteristics, which affected the amount of nursing care, varied according to each DPC code. The major factors affecting the amount of nursing care were whether the patient had received a surgical (under general anesthetics) treatment or a non-surgical treatment and the level of activities of daily living (ADL) of the hospitalized patients. For those who had received a surgical operation for colon cancer, the patient's age also affected the amount of nursing care. **Conclusions:** The findings show that the method for the visualization of the amount of nursing care based on the classification of patient characteristics can be implemented into the electronic health record system. This method can then be used as a management tool to assure appropriate distribution of nursing resources.

## 1. Introduction

The Diagnosis Procedure Combination (DPC) is a global assessment system based on the standardization and visualization of medical data. This system was introduced into the Japanese medical system after its reformation [1]. Since the introduction of the DPC system, medical data

have been used secondarily to promote the standardization of medical care as the following studies show.

Recent studies have shown the benefits of using the DPC system as well as the Nursing Minimum Data Set (NMDS). The use of the DPC system in studies conducted in Japan displayed the advantages of using standardized data to analyze large numbers of patients and to evaluate procedures [2,3,4]. Moreover, studies using the NMDS, were conducted successfully in Western countries (the U.S., Belgium, and Austria), and showed the benefits of using standardized data to analyze various aspects of nursing care performed on large groups of patients [5,6,7,8].

The number of elderly patients in acute-phase medical institutions has been increasing due to Japan's rapidly aging population. At the same time, the average number of days of hospitalization in acute-phase medical institutions has been reduced by the introduction of the DPC system or functional differentiation of medical facilities. Consequently, it has become even more important to distribute nursing resources appropriately and assure the quality of nursing practice during a short hospital stay. Therefore, it is necessary to visualize nursing care provided to the patients and make analyses and assessments from both qualitative and quantitative aspects.

The DPC system basically refers to the amount of medical resources provided. However, factors associated with nursing, the field providing the greatest workforce, have not been reflected in this concept. The main reason for this is that the standardization of nursing information in Japan has not been ascertained, and there has been no way to quantify the amount of nursing care provided to patients.

Uto et. al. developed a nursing system for the visualization and quantification of the amount of nursing care offered to patients [9,10]. We used this nursing system in our study to clarify the relationship between patient characteristics and the amount of nursing care.

### **1.1. Prospective payment system in DPC**

The prospective payment period in the DPC system has been divided into three periods. (In the DPC system a DPC code is attached to each diagnosis.) The standard hospitalization period for each DPC code is defined as Period II. When the hospitalization period is shorter than 25%, it is defined as Period I (Figure 1). When the hospitalization period is 25% longer or more than Period I, it is defined as Period III, which is when the upper limit of the prospective payment period is reached. In this study, patients hospitalized for the duration of Periods I, II and III were included in the analyses.

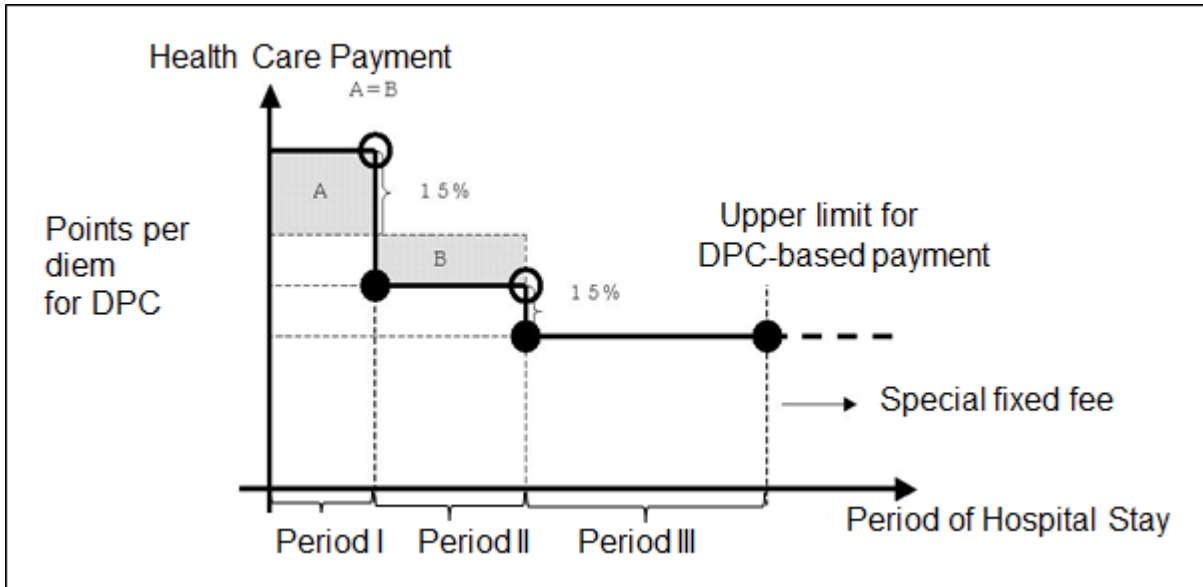

Figure 1 Relationship between DPC scores and duration of hospitalization

### 1.2. Nursing system in the study setting

The nursing system, which has been used in a university hospital since 1987, is “The Nursing Care Intensity Classification System of Kagoshima University,” which was developed by further subdividing nursing care intensity and standardized by the Ministry of Health, Labour and Welfare of Japan [9].

Moreover, this classification system was reestablished in 2007 by connecting patient categorization, based on reasons for hospitalization and patients’ state of health, with nursing care intensity. This connection was made so that the nursing care provided directly to the patients could be quantified using nursing plans and data obtained from nursing practice records.

In this classification system, a “care set,” a series of nursing care activities, is provided considering the patients’ conditions as problematic factors. Using this “care set,” the nurses create a nursing plan by adding or eliminating nursing care activities according to the individual patient’s condition.

Also, Uto et. al. conducted a time study of nursing care activities by analyzing each nursing care activity of 500 nurses over a period of two weeks [10]. Then, after the median value was inputted into the nursing care master table, the quantification of nursing care was achieved.

### 1.3. Definition of terms

The amount of nursing care in this study indicates the amount of nursing care directly provided at the patient’s bedside (time: minutes). Nursing care intensity level indicates the intensity of observations made on all symptoms of the patients, including their medical and cognitive states. Level of mobility indicates the patients’ abilities in activities of daily living (ADL). Type of transportation is used to assess the method of patient transportation on the basis of general evaluations made by the nurses. The definitions of these terms are presented in Table 1.

Table1 Terms of Definition

	Term	Definition
Nursing Care Intensity	Intensity level A	Constant observation required
	Intensity level B	Continuous observation required (roughly every 1-2 hrs.)
	Intensity level C	Intermittent observation required
Level of Mobility	Level I	Confined to bed (bedridden)
	Level II	Some movement in bed
	Level III	Ability to walk in the room
	Level IV	Ability to walk with complete independence
Types of Transportation	Stretcher	Transport by stretcher
	Escort	Transport by wheelchair
	Independent	Walking independently

## 2. Objectives

The purpose of this study was to improve accessibility to nursing care by clarifying the relationship between patient characteristics and the amount of nursing care for the DPC system.

## 3. Method

### 3.1. Subjects and study period

The subjects included patients who were hospitalized from July 1, 2008, to March 31, 2010, in a university hospital and registered with the following six-digit DPC codes: 528 lung cancer patients with the DPC code 040040; 170 gastric cancer patients with the DPC code 060020; and 91 colon cancer patients with the DPC code 060035. The patients who were discharged upon death were excluded from the analysis. Since DPC codes are reviewed every two years according to technological progress in medicine and diagnostic methods are assessed in order to reestablish the DPC system, we conducted analyses on diseases that were observed in the largest number of patients during the period categorized for the same DPC code.

### 3.2. Data extraction method

The hospital data warehouse was developed by Muranaga et. al. for the purpose of performing various kinds of analyses on data generated from the hospital information system (HIS) [11]. They used the hospital data warehouse to develop a data mart for the purpose of discovering the main cause of treatment cost per DPC.

In this study the hospital data warehouse was also used to extract patient data through the use of DPC codes. The extracted data included the patient's age, sex, the number of days hospitalized, method of surgery, nursing care intensity level, level of mobility, types of transportation, and the types and amount of nursing care.

### 3.3. Analysis method

The data obtained were processed as follows using the statistical analysis software, SPSS Statistics 20 and the open source software R, ver2.12.2.

(1) Nursing care included various kinds of nursing care activities such as the measurement of vital signs, whole-body cleaning, and assistance when moving. With regard to the amount of nursing care provided, the time set to a nursing care master table was quantified by calculating the time required for one person to complete all nursing care activities in one day. Some of the major nursing care activities performed are listed in Table 2.

Table 2 Nursing Care Activities

Measurement	Time (minutes)	Observation	Time (minutes)	Medical Examination Assistance	Time (minutes)	Assistance in Daily Living	Time (minutes)	Education/Advice	Time (minutes)
Measurement of body temperature	3	Level of consciousness	1	Collection of venous blood sample	3	Application of cold compress	2	Nutrition education	5
Measurement of pulse rate	3	Pharyngodynia	1	Intravenous drip management	1	Bed bath	10	Prevention of infection	3
Measurement of blood pressure	3	Edema	1	Oxygen inhalation therapy	1	Foot bath	10	Discharge orientation	5
Measurement of respiratory rate	5	Abdominal pain	1	Catheter management	3	Stoma care	5	Instruction on the use of drugs	3
Measurement of oxygen saturation	5	Lassitude	1	Sputum suction	5	Tube feeding	2	Prevention of pressure ulcers	5
Measurement of urine volume	2	Jaundice	1	Wound treatment	5	Turning or positioning	2	Preoperative nursing care	5

(2) After performing the data normality test for each DPC code, relationships between the amount of nursing care and nursing care intensity level, level of mobility, and types of transportation were analyzed using the Spearman's rank correlation coefficient.

(3) Hierarchical cluster analyses were performed using variables with which correlations were observed at the significance level of less than 0.01 in (2), and then the subjects were categorized into groups. The Ward's method was used to measure the distance between clusters.

(4) The parameters for the distinctive features of each cluster were discovered by the use of the Association Analysis. The statistics software used was apriori of the arules library of the statistical analysis software R, ver2.12.2.

(5) After the discovered parameters were adjusted and compared to the cluster analyses, an evaluation of the parameters was performed. A decision tree was then used for the analyses of patient characteristics. The decision tree clarified in what order the patient characteristics had been clustered.

(6) In order to make comparisons on factors such as the amount of nursing care provided and the patient's age, the Mann-Whitney U test was performed between two groups. The Kruskal-Wallis test was used among three groups, after performing the data normality test.

### 3.4. Ethical concerns

The ethics committee of the research facility at a university hospital has approved this study. Data that could identify patients were eliminated during the process of data collection, input or analysis.

Then the data were analyzed as unconnected and anonymous information.

## 4. Results

### 4.1. Overview of subjects

The subjects' age, the number of days hospitalized, and the amount of nursing care provided during the hospital stay are shown in Table 3. The disease observed at the highest mean age was gastric cancer, and the greatest amount of nursing care was provided to the lung cancer patients.

Table 3 Median value (range) of patient overviews in each DPC code

	Patient's Age	Number of days hospitalized (days)	Amount of nursing care (minutes)
Lung cancer (n=528)	66.0 (58.0-75.0)	15.0 (7.0-24.0)	88.3 (68.5-106.0)
Gastric cancer (n=170)	71.0 (60.0-79.0)	15.0 (9.0-25.3)	78.8 (59.5-101.3)
Colon cancer (n=91)	64.0 (57.0-73.0)	9.0 (5.0-25.0)	83.0 (65.0-118.0)

### 4.2. Factors affecting the amount of nursing care in each DPC code

The factors that could affect the amount of nursing care in each DPC code were analyzed using the Spearman's rank correlation coefficient and a significance level of less than 0.01 was observed. The minimum of the Spearman's rank correlation coefficient was observed at the significance level of 0.4. The following results were obtained.

#### Lung cancer patients

A positive correlation was found between the amount of nursing care provided to lung cancer patients and the following variables: nursing care intensity level A ( $r_s=0.581$ ); level of mobility I ( $r_s=0.511$ ); transport by stretcher ( $r_s=0.054$ ); and transport by escort ( $r_s=0.416$ ). These results revealed that the lung cancer patients' need for constant observation and complete assistance in ADL affected the amount of nursing care provided.

#### Gastric cancer patients

A positive correlation was found between the amount of nursing care provided to gastric cancer patients and the following variables: number of days hospitalized ( $r_s=0.447$ ); nursing care intensity level A ( $r_s=0.498$ ); level of mobility I ( $r_s=0.419$ ); level of mobility II ( $r_s=0.433$ ); level of mobility III ( $r_s=0.553$ ); and transport by escort ( $r_s=0.539$ ). These results revealed that the gastric cancer patients' need for constant observation and partial assistance in ADL affected the amount of nursing care provided.

#### Colon cancer patients

A positive correlation was found between the amount of nursing care provided for colon cancer patients and the following variables: the number of days hospitalized ( $r_s=0.646$ ); nursing care

intensity level B ( $rs=0.792$ ); nursing care intensity level B ( $rs=0.530$ ); level of mobility I ( $rs=0.653$ ); level of mobility II ( $rs=0.568$ ); transport by stretcher ( $rs=0.568$ ); and transport by escort ( $rs=0.589$ ). These results revealed that the colon cancer patients' need for constant or intermittent observation and complete assistance in ADL affected the amount of nursing care provided.

### 4.3. Grouping of patients according to hierarchical cluster analyses

Hierarchical cluster analyses were performed on variables correlating with the amount of nursing care provided, using the Spearman's rank correlation coefficient. The Ward's method was used to measure the distance between clusters.

#### Lung cancer patients

For lung cancer patients with malignant tumors, hierarchical cluster analyses were performed using data on the following characteristics: nursing care intensity level A; level of mobility I; transport by stretcher and transport by wheelchair. Figure 2 shows the dendrogram created from the data for the lung cancer patients.

These patients were categorized into the following four groups: 298 patients in Cluster 1; 59 patients in Cluster 2; 163 patients in Cluster 3; and 4 patients in Cluster 4.

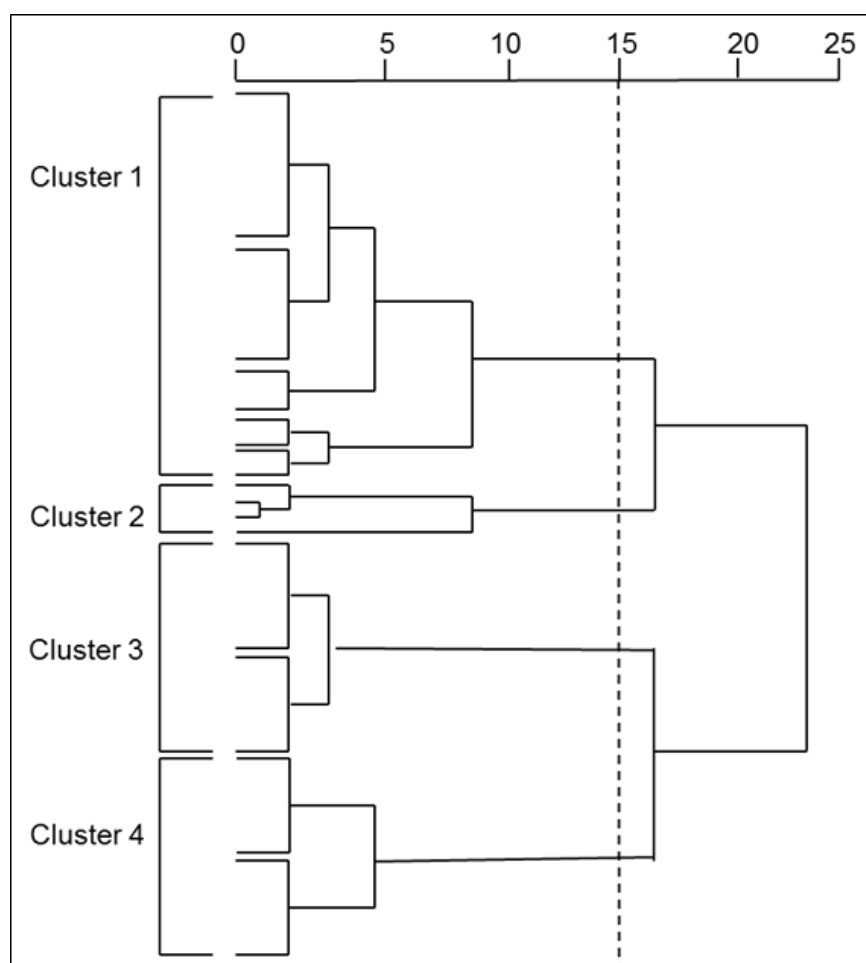

Figure 2 Dendrogram of lung cancer patients with malignant tumors

### Gastric cancer patients

For gastric cancer patients with malignant tumors, hierarchical cluster analyses were performed using data on the following characteristics: number of days hospitalized; nursing care intensity level A; level of mobility I; level of mobility II; level of mobility III; and the number of days a wheelchair was required. Figure 3 shows the dendrogram created from the data for the gastric cancer patients.

These patients were categorized into three groups: 89 patients in Cluster 1; 80 patients in Cluster 2; and 1 patient in Cluster 3.

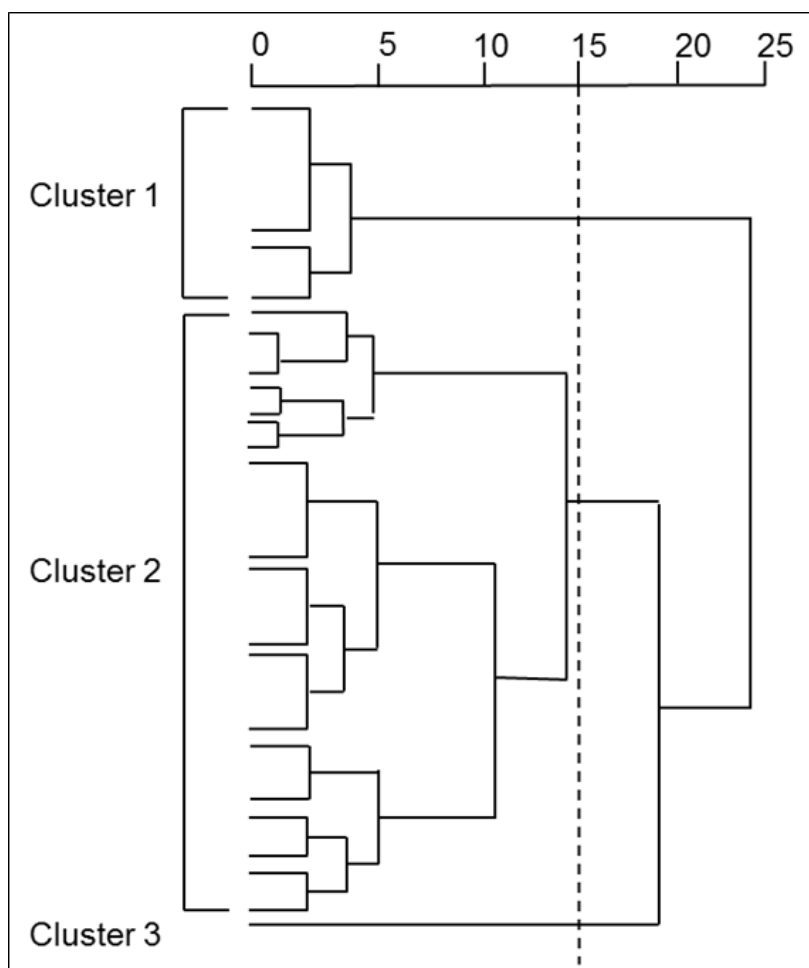

Figure 3 Dendrogram of gastric cancer patients with malignant tumors

### Colon cancer patients

Hierarchical cluster analyses for colon cancer patients with malignant tumors were performed using data on the following characteristics: number of days hospitalized; nursing care intensity level A; nursing care intensity level B; level of mobility I; level of mobility III; the number of days a stretcher was required and the number of days a wheelchair was required. Figure 4 shows the dendrogram created from the data for the colon cancer patients.

These patients were categorized into three groups: 69 patients in Cluster 1; 21 patients in Cluster 2; and 1 patient in Cluster 3.



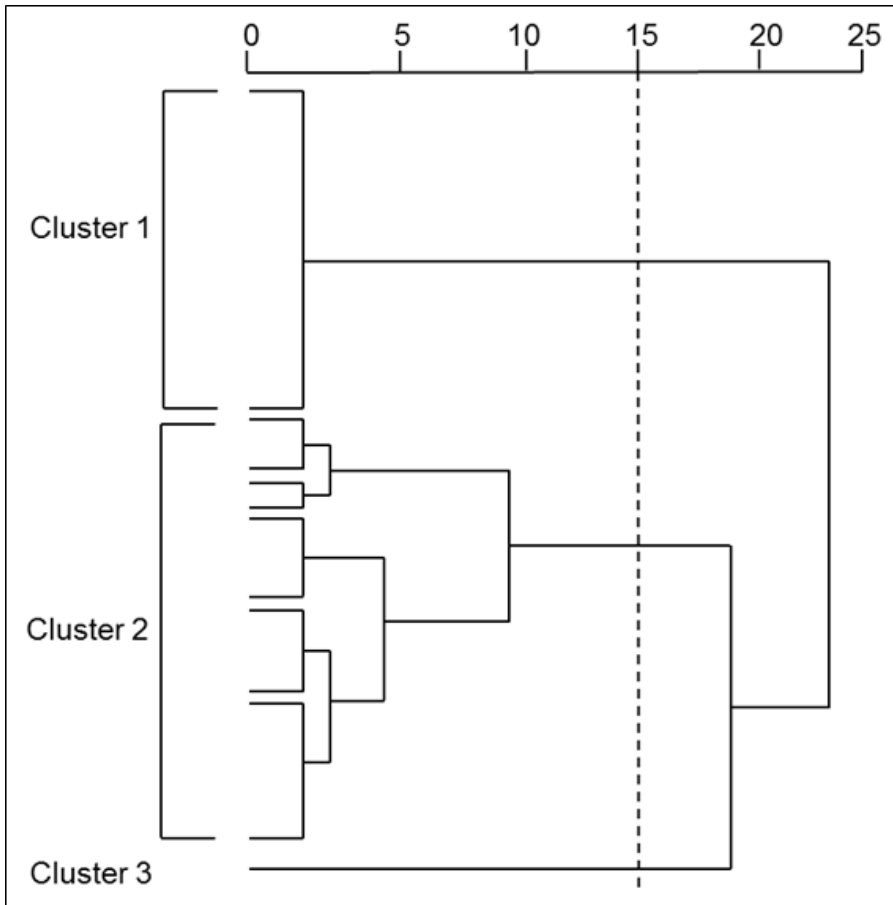

Figure 4 Dendrogram of colon cancer patients with malignant tumors

#### 4.4. Analyses of patient characteristics using a decision tree

The parameters for the distinctive features of each cluster were discovered by the use of Association Analysis. Association analysis identifies relationships or correlations between observations and / or between variables in data sets [12]. These relationships are then expressed as a collection of so-called association rules. The two primary measures used in association analysis are support value and confidence value.

After data were analyzed for each cluster, analyses were conducted on the data that would represent the parameters, such as the type of transportation required at admission; the type of transportation required at discharge; age; and whether a surgical operation was performed. Then items were inputted and analyzed (minimum support value of 0.1 and minimum confidence value of 0.8).

As a result, the support value of 0.356364 and confidence value of 0.894977 were found for the following representative parameters for Cluster 1 lung cancer patients with malignant tumors: those who were scheduled for hospital admission; those who required or did not require an ambulance; those who did not require assistance in walking at admission; and those who received non-surgical treatment. Also the results from the analyses of patients in other clusters showed that the parameters were the following: the purpose of hospital admission; whether there was a need for an ambulance; the type of transportation required at admission; the type of transportation required at

discharge; and whether there was a need for a surgical operation.

Gastric and colon cancer patients with malignant tumors were analyzed in the same way as above. The following parameters for gastric cancer patients were found: the type of transportation required at admission; the type of transportation required at discharge; whether there was a need for a surgical operation; and the final outcome of the disease and age.

The following parameters for colon cancer patients were found: the purpose of hospitalization; the type of transportation required at admission; whether there was a need for a surgical operation; sex; and age.

Next, the parameters were evaluated and adapted to the decision tree in order to generalize the representative parameters. Then, after comparing the results obtained from the decision tree and the hierarchical cluster analyses, similarities were investigated. It was found that other institutions could use the parameters that were adapted to the decision tree in this study.

### **Lung cancer patients**

For the decision tree of lung cancer patients with malignant tumors, seven clusters were created from four parameters and terminals, resulting in the overall correct classification rate of 81.8% (Figure 5).

Cluster 1 lung cancer patients exhibited the following characteristics: the requirement of non-surgical treatment and independence in ADL; the need to receive a diagnosis or treatment; and the need for partial assistance in ADL.

Around 92.0 % of the Cluster 3 lung cancer patients were those who received surgery and the main patient characteristic was receiving a surgical operation.

According to the analysis of the decision tree, Cluster 2 and Cluster 4 lung cancer patients were categorized in the same way but the nursing care intensity level differed between these two clusters. Cluster 2 patients required nursing care at intensity level B, which meant that they required intermittent observation for a long time. On the other hand, Cluster 4 patients required nursing care at intensity level A; that is, they required constant observations for a long time (Table 4).

The main characteristics for Cluster 2 and Cluster 4 lung cancer patients were also found. The patient characteristics for Cluster 2 were the requirement of non-surgical treatment, the need for partial assistance in ADL and the requirement for nursing care at intensity level B for a very long time (number of days). On the other hand, the patient characteristics for Cluster 4 were the requirement of non-surgical treatment, the need for partial assistance in ADL and the requirement for nursing care at intensity Level A for a very long time (number of days).

In terms of the decision tree for lung cancer patients with malignant tumors, treatment purpose became a useful parameter for patients requiring non-surgical treatment. Therefore, patients who received chemotherapy were analyzed (Figure 6). However, because the data for chemotherapy patients was insufficient, it was not possible to use it as a patient characteristic for each cluster.

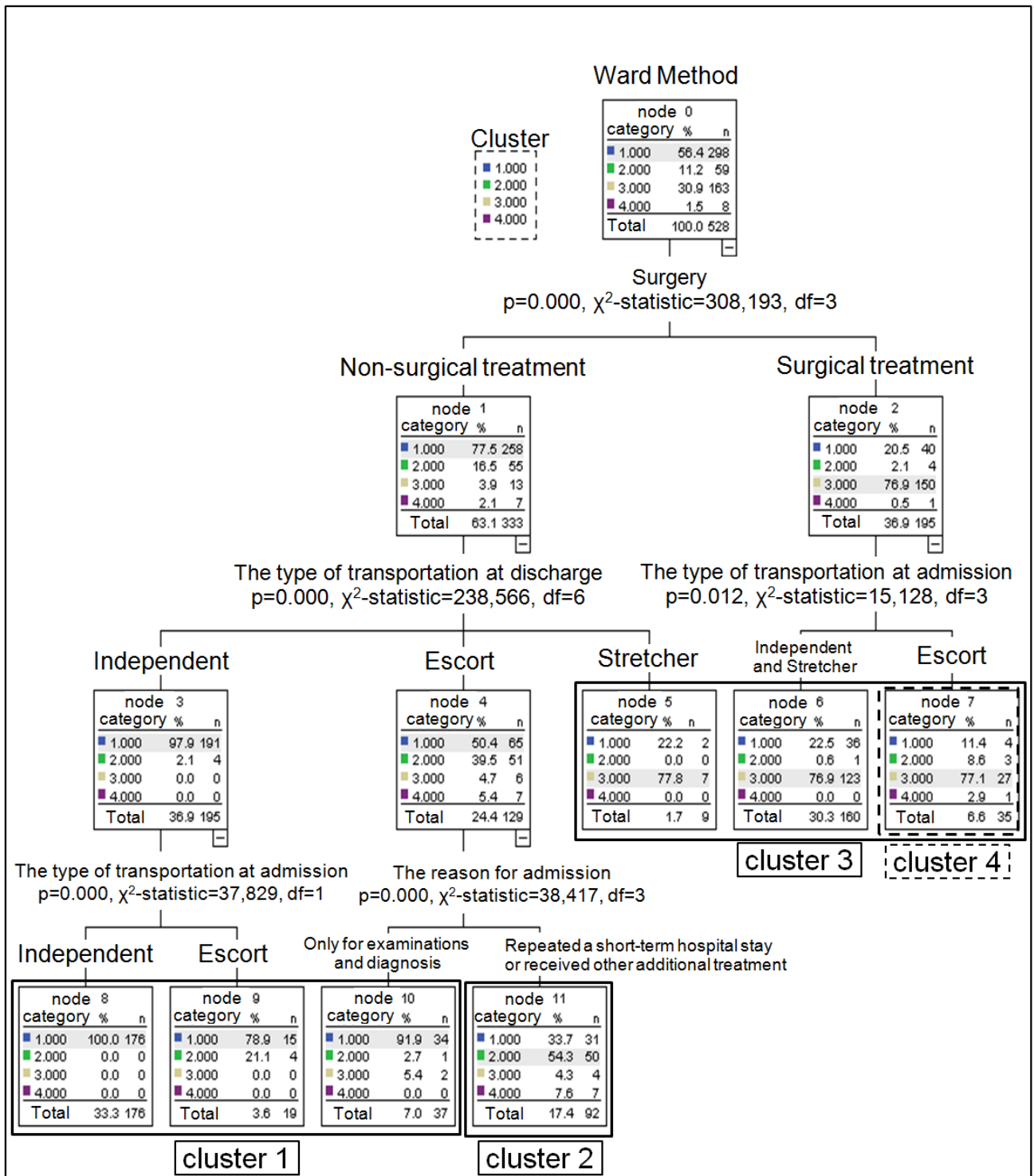

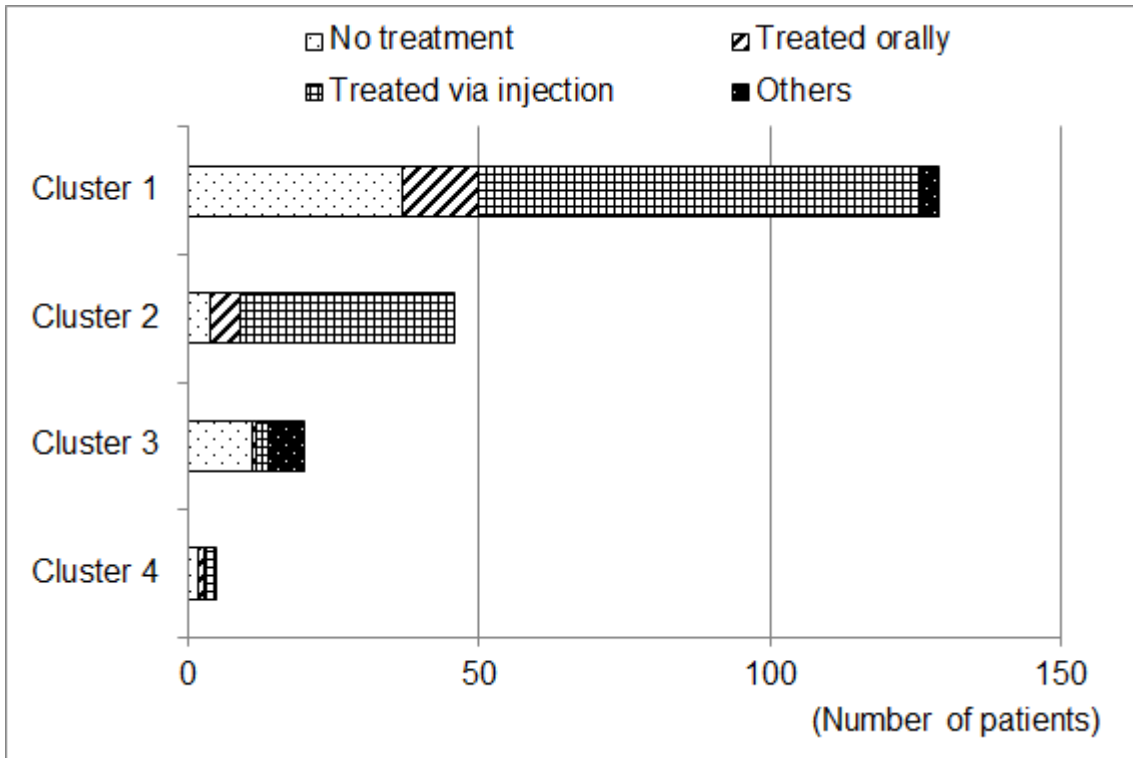

Figure 6 Number of patients who received cancer chemotherapy for lung cancer

**Gastric cancer patients**

For the decision tree of gastric cancer patients with malignant tumors, five clusters were created from three parameters and terminals, resulting in the overall correct classification rate of 87.1% (Figure 7).

The main characteristics for Cluster 1 gastric cancer patients were the requirement of either surgical or non-surgical treatment and the requirement of either complete or partial assistance in ADL.

The main characteristics for Cluster 2 gastric cancer patients were the requirement of non-surgical treatment and independence in ADL.

The Cluster 3 gastric cancer patient exhibited the characteristics of requiring partial assistance in ADL at admission and requiring nursing care at intensity level A for a very long time (number of days) (Table 5). This patient had a sequela of stroke as a complication at admission.

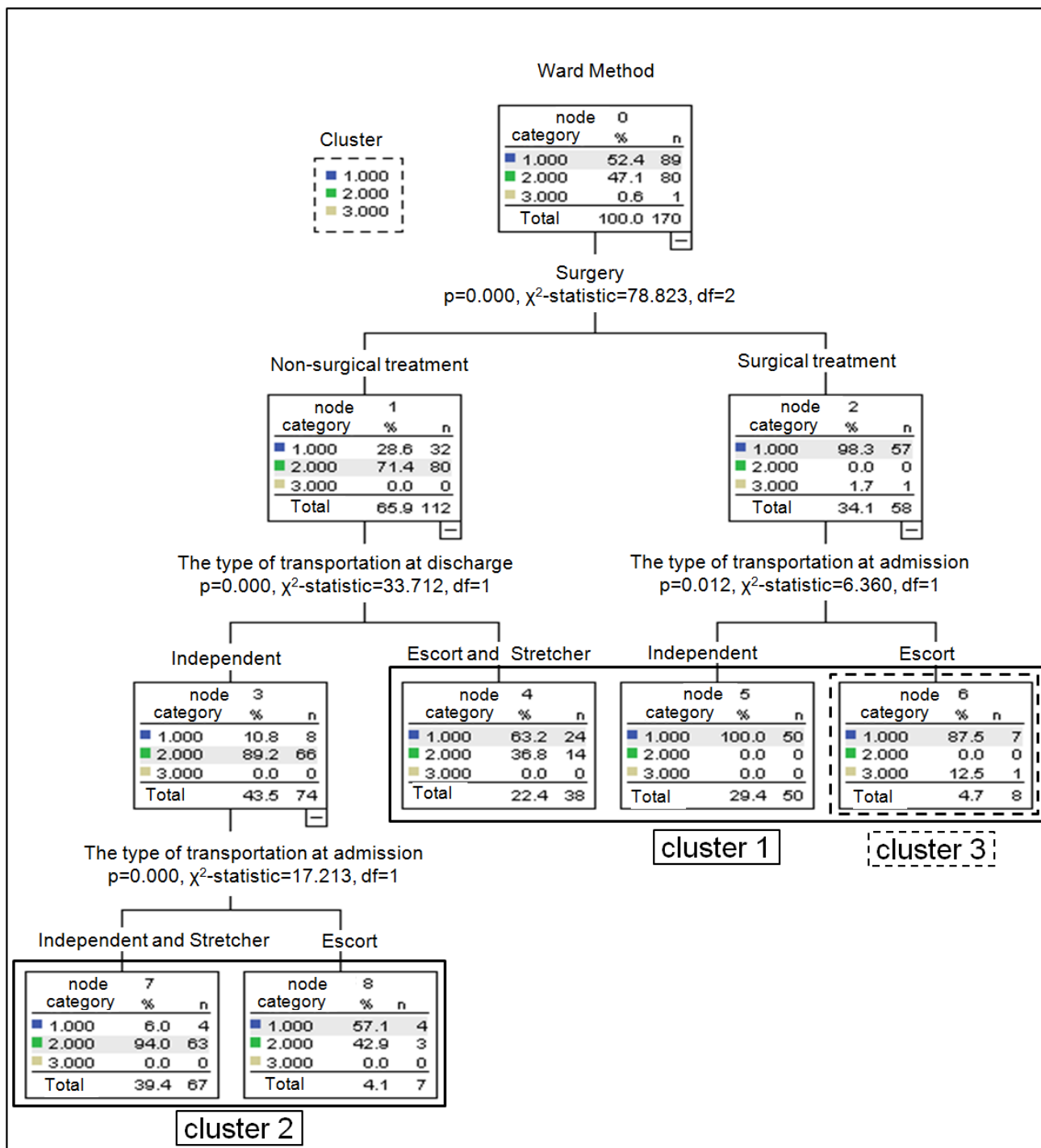

Figure 7 A decision tree established for gastric cancer patients

### Colon cancer patients

For the decision tree of colon cancer patients with malignant tumors, six clusters were created from three parameters and terminals, resulting in the overall correct classification rate of 92.3% (Figure 8).

The DPC code for colon cancer patients differed from other DPC codes and the distinguishing features of these patients were the following: they were classified according to their level of ADL and according to whether they had received a surgical operation.

The patient characteristics for Cluster 1 were the requirement of non-surgical treatment and the need for either complete or partial assistance in ADL or the requirement of surgical treatment and independence in ADL for patients over the age of 65.

The Cluster 3 colon cancer patient exhibited the characteristics of requiring complete assistance in ADL and requiring nursing care at intensity level A for a very long time (number of days) (Table 6). This patient had received a surgical operation and had complications including hemorrhagic shock and ileus at admission.

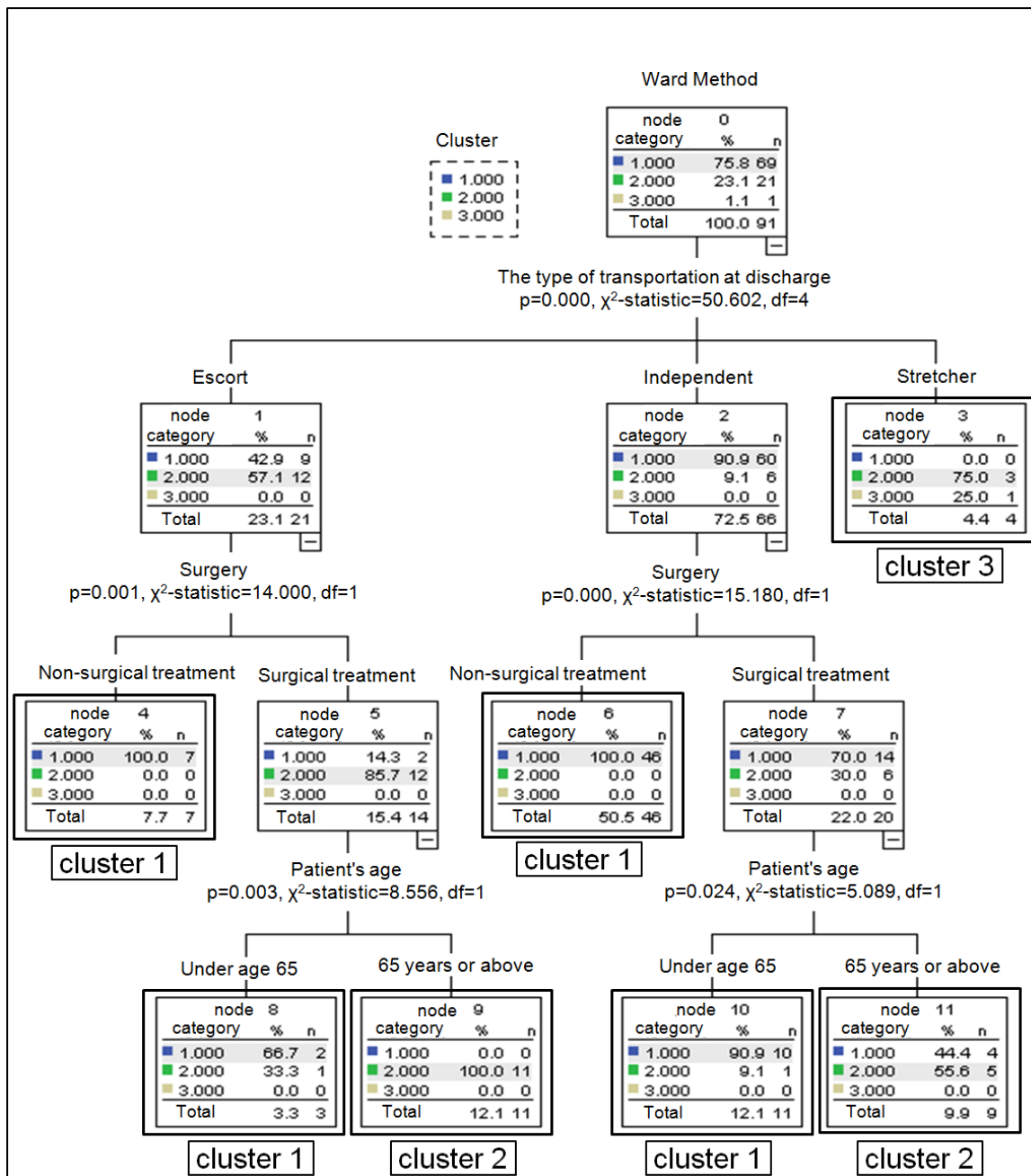

Figure 8 A decision tree established for colon cancer patients

#### 4.5. Relationships between patient characteristics and the amount of nursing care provided in each cluster

##### Lung cancer patients

Analyses were performed on the relationship between the patient characteristics and the amount of nursing care provided in each cluster, clarified by the decision tree.

The amount of the nursing care provided was the smallest for Cluster 1 lung cancer patients who received non-surgical treatment and who needed the most help in ADL (Table 4). However, the amount of nursing care was greater for Cluster 2 patients than for Cluster 1 patients and a statistically significant difference was observed ( $p < 0.01$ ).

Furthermore, it was found that the greatest amount of nursing care was provided to Cluster 4 lung cancer patients (not categorized into Cluster 2) who had received non-surgical treatment and required partial assistance in ADL. In Cluster 2 and Cluster 4 a statistically significant difference was observed only in the amount of nursing care ( $p < 0.01$ ). The results also showed that the Cluster 2 and Cluster 4 patient characteristics of receiving non-surgical treatment and requiring partial assistance in ADL were the same.

However, as mentioned previously in 3.3, it was found that the requirement of a large amount of nursing care was related to nursing care intensity level A; that is, the patient's condition required constant observation.

Table 4 Overview of the median value (range) of each cluster in lung cancer patients

	Patient's Age	Number of days of hospitalization (Days)	Amount of nursing care (Minutes)	Nursing care intensity Level A (Days)	Nursing care intensity Level B (Days)	Nursing care intensity Level C (Days)
Cluster 1	64.0(57.0-74.0)	10.0(4.0-21.0)	76.0(61.0-93.1)	0.0(0.0-1.0)	8.0(3.0-19.3)	0.0(0.0-0.0)
Cluster 2	68.0(63.0-76.0)	30.0(24.0-44.0)	91.0(81.0-107.5)	0.0(0.0-1.0)	29.0(22.0-43.0)	0.0(0.0-0.0)
Cluster 3	68.0(61.0-77.0)	16.0(13.0-22.0)	107.0(95.0-124.5)	4.0(2.0-5.0)	11.0(7.0-16.0)	0.0(0.0-2.0)
Cluster 4	73.0(48.8-78.8)	34.0(24.3-66.3)	125.0(117.0-166.3)	26.5(21.5-38.5)	3.0(0.5-24.0)	0.0(0.0-0.0)

##### Gastric cancer patients

In the analysis of gastric cancer patients with malignant tumors, it was found the amount of nursing care provided was first affected by the characteristic of whether a surgical operation was received and then by the characteristic of ADL (Table 5).

It was also found that the same amount of nursing care was required for surgical patients and Cluster 1 gastric cancer patients who received non-surgical treatment and needed minimum assistance in ADL.

The amount of nursing care provided was greater in Cluster 1 than in Cluster 2 gastric cancer patients, and a statistically significant difference was observed as well ( $p < 0.01$ ). On the other hand, the amount of nursing care provided to the gastric cancer patient in Cluster 3 was more than twice as much as the amount provided to the other patients. It was revealed that this patient required the greatest amount of nursing care not only because he required complete assistance in ADL due to the sequela of stroke, but also because his condition required constant observation throughout the course

of the hospital stay.

**Table 5 Overview of the median value (range) of each cluster in gastric cancer patients**

	Patient's Age	Number of days of hospitalization (Days)	Amount of nursing care (Minute)	Nursing care intensity Level A (Days)	Nursing care intensity Level B (Days)	Nursing care intensity Level C (Days)
Cluster 1	72.0(59.5-79.5)	24.0(18.0-30.5)	94.0(78.8-112.3)	4.0(1.0-7.0)	18.0(12.5-24.5)	0.0(0.0-0.0)
Cluster 2	71.5(61.0-78.8)	9.0(4.0-13.0)	63.0(52.3-77.9)	0.0(0.0-0.0)	5.0(3.0-11.0)	0.0(0.0-0.8)
Cluster 3	74.0	57.0	244.0	40.0	17.0	0.0

### **Colon cancer patients**

In colon cancer patients, factors such as ADL and the age of the patients who received surgery affected the amount of nursing care provided (Table 6). The patients who had received a surgical operation at the age of 64 or below were categorized into Cluster 1 with other patients who received non-surgical treatment, and were either independent or required partial assistance in ADL. The patients who received surgery at the age of 65 or above and required complete assistance in ADL were categorized into Cluster 2. The amount of nursing care was greater for Cluster 2 than for Cluster 1, and a statistically significant difference was also observed ( $p < 0.01$ ).

On the other hand, the amount of nursing care required for the Cluster 3 colon cancer patient was more than twice the amount required for patients in the other clusters. The Cluster 3 patient required a greater amount of nursing care not only because he required complete assistance in ADL, but also because he had developed hemorrhagic shock and ileus at admission. Thus, his condition required a prolonged amount of time (for nursing care), which required constant observation.

**Table 6 Overview of the median value (range) of each cluster in colon cancer patients**

	Patient's Age	Number of days of hospitalization (Days)	Amount of nursing care (Minute)	Nursing care intensity Level A (Days)	Nursing care intensity Level B (Days)	Nursing care intensity Level C (Days)
Cluster 1	64.0(55.0-67.0)	6.0(4.0-15.0)	75.5(60.5-93.3)	0.0(0.0-2.5)	5.0(4.0-10.0)	0.0(0.0-0.0)
Cluster 2	77.0(72.5-80.0)	31.0(26.5-43.0)	124.5(104.8-167.5)	8.0(5.0-15.5)	23.0(14.5-28.0)	0.0(0.0-0.0)
Cluster 3	83.0	71.0	331.0	36.00	35.00	0.00

## **5. Discussion**

### **5.1. Patient characteristics which affect the amount of nursing care provided**

In this study, patients were categorized into groups according to the factors that might affect the amount of nursing care in each DPC code, and analyses were made on the patient characteristics using a decision tree.

Lee, A. H. et. al. conducted research on the relationship between the prolongation of hospitalization and patient characteristics using the Diagnosis Related Groups (DRG) system and reported that the results from study revealed important information for hospital management [13].

The results from this study were used to classify patient characteristics according to the patient type and the amount nursing care required in each DPC code (Figures 9 - 11). The patient characteristics, which affected the amount of nursing care, differed according to the DPC code. The main factors affecting the amount of nursing care were whether the treatment was surgical (involving the use of



the anesthetics) or non-surgical; and the level of ADL of hospitalized patients. Furthermore, age was a factor associated only with colon cancer patients who were hospitalized.

### **Lung cancer patients**

The characteristics of lung cancer patients were categorized into four types (Figure 9). These patients were roughly categorized as those who received surgery and those who received a non-surgical treatment. Also, ADL affected the amount of nursing care provided only in patients who received non-surgical treatment.

With regard to the lung cancer patients' ADL, the amount of nursing care required increased proportionally to the level of assistance required for ADL.

Thus, the amount of nursing care provided to the Type Z lung cancer patients who required complete assistance (in Figure 9) was equivalent to the amount of nursing care provided to surgical patients.

However, it was not possible to categorize some patients who received non-surgical treatment only by ADL.

In terms of nursing care intensity levels, the frequency of observations varied according to the lung cancer patients' condition, such as the severity of the disease or the state of consciousness. Thus, the nursing care was at intensity level A when constant observation was necessary due to patients' unstable vital signs, physical instability or deliriousness. On the other hand, the nursing care was at intensity level B or level C when the patients' medical condition stabilized or when the condition of bed-ridden patients had stabilized.

During their hospital stay, Type W lung cancer patients (in Figure 9) required not only the greatest amount of nursing care but also the longest the number of days with nursing care at intensity level A. Also, these patients required partial assistance in ADL and had to be constantly observed for a long time.

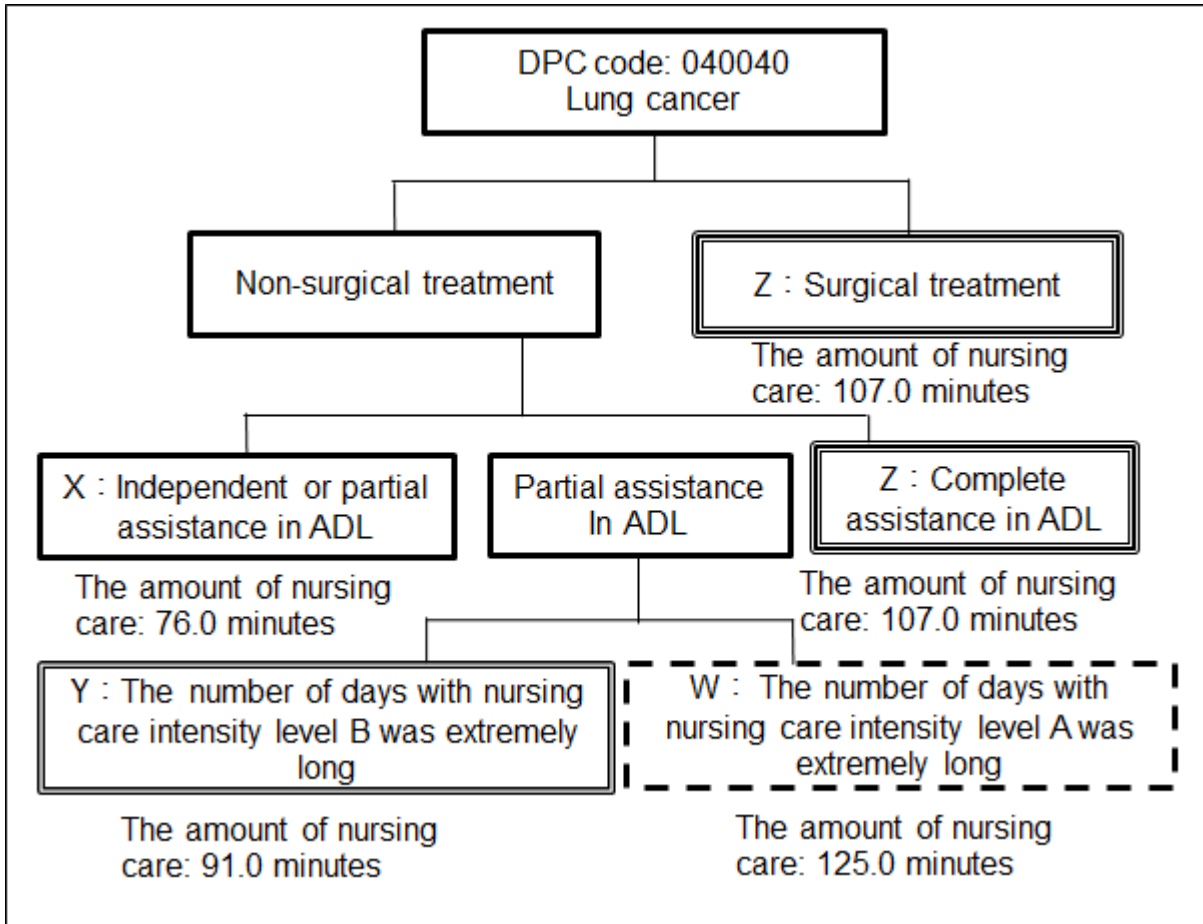

Figure 9 The amount of nursing care based on the classification of lung cancer patient characteristics

**Gastric cancer patients**

The characteristics of gastric cancer patients were categorized into three types. These patients were roughly categorized into those who received surgery or those who received non-surgical treatment (Figure 10). The amount of nursing care provided to the Type Y gastric cancer patients (in Figure 10), who received non-surgical treatment and required partial or complete assistance, was equivalent to the amount of nursing care provided to surgical patients.

There was one Type Z gastric cancer and there was also a Type Y gastric cancer patient who required partial assistance in ADL at admission. It was suggested that the difference between these two patients was the number of days requiring nursing care at intensity level A during the hospital stay, which was also a difference between some of the lung cancer patients.

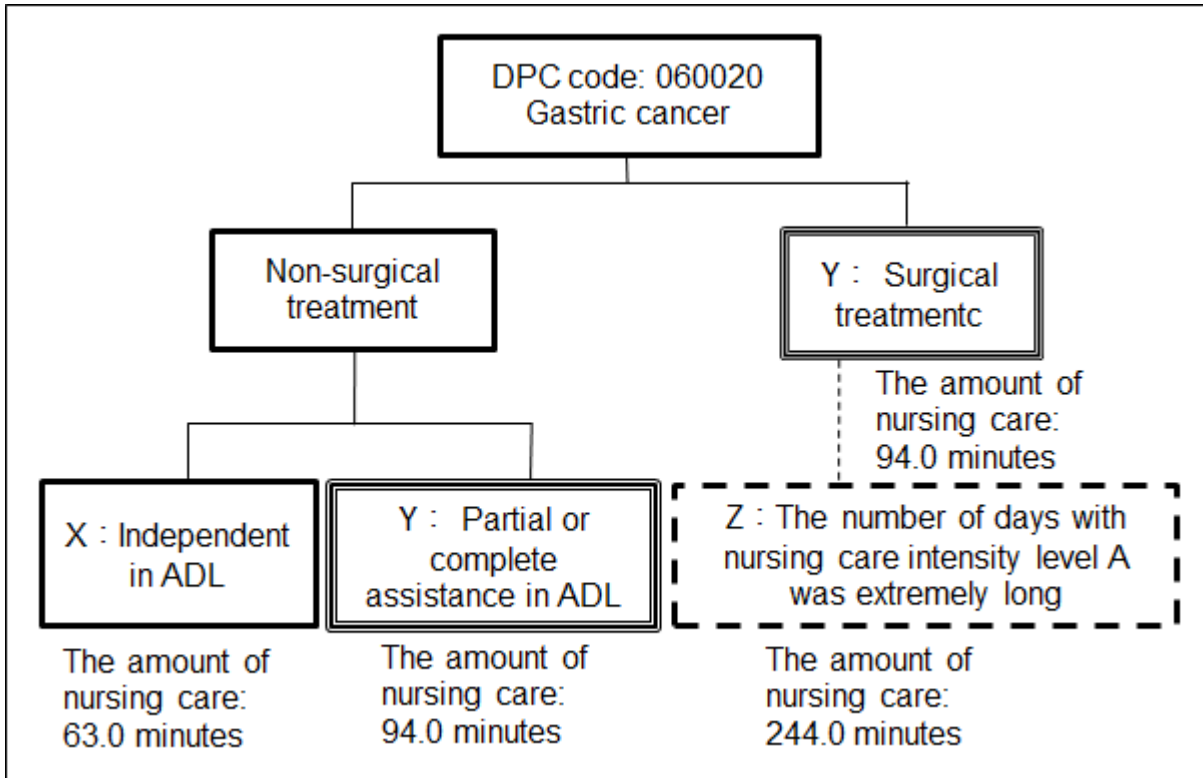

Figure 10 The amount of nursing care based on the classification of gastric cancer patient characteristics

### Colon cancer patients

The characteristics of colon cancer patients with malignant tumors were categorized into three types (Figure 11). Unlike other DPC codes, colon cancer patients were classified by their ADL. Surgical patients aged 65 or above who were independent or required partial assistance in ADL, and patients who required complete assistance in ADL were categorized as Type Y colon cancer patients.

There was one Type Z colon cancer patient and there was also a Type Y colon cancer patient who required complete assistance at discharge. The differences between these patients seemed to include the number of days requiring nursing care at intensity level A during the hospital stay, as seen in other DPC codes.

However, the effect of surgery was also considered as the Type Z patient had received surgery. Thus, it was not clear if the Type Z patient had been categorized by the number of days with nursing care at intensity level A or by surgery. On the other hand, this patient's main characteristic, requiring the longest number of days with nursing care at intensity level A during the hospital stay, was consistent with that of other DPC codes.

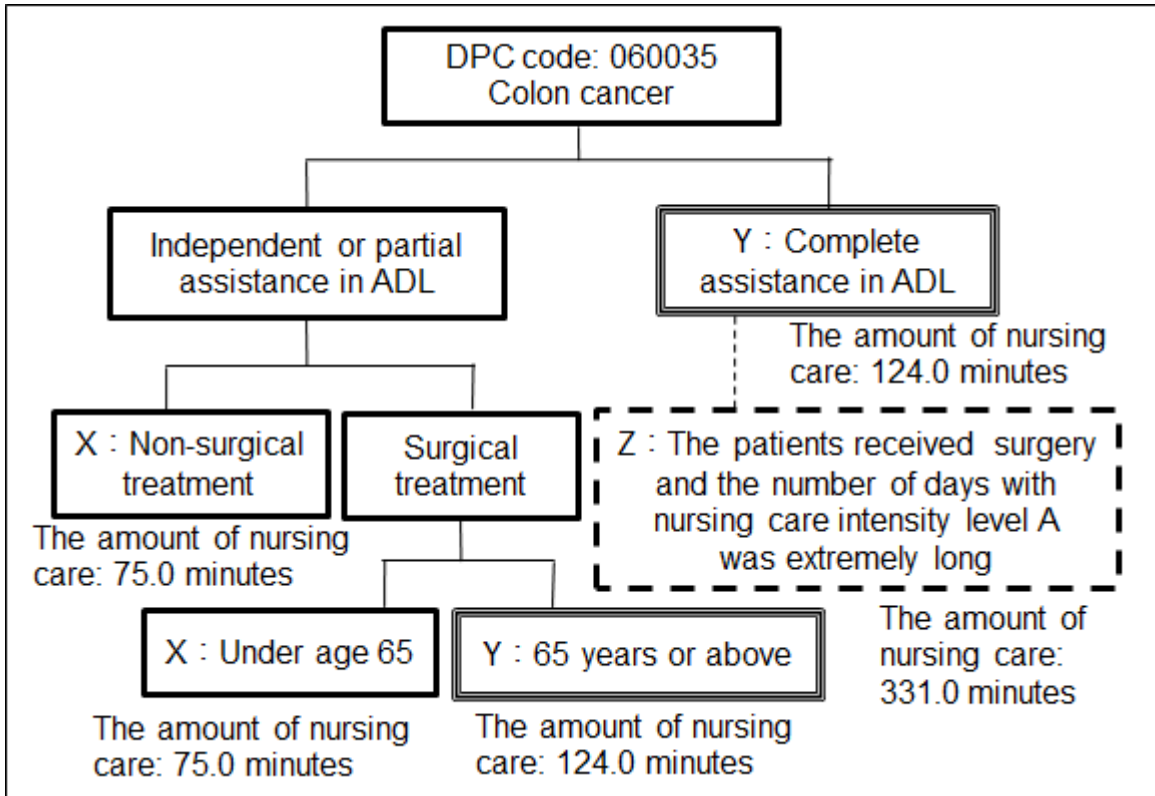

Figure 11 The amount of nursing care based on the classification of colon cancer patient characteristics

“The Nursing Care Intensity Classification of Kagoshima University,” which was used in this study as an index, was developed by linking the patients’ categorization method, namely, the reason for hospitalization (treatment, test, education, labor), with the records of nursing care practice provided to the patients. This certainly allows us to know the patients’ demand for nursing care. Accumulation of nursing care records of all nursing care activities performed daily enables us to make a quantitative assessment through the secondary use of these data. With this classification system, we will be able to provide efficient and high quality nursing care that is based on evidence.

**5.2. Accessibility to nursing care according to patient characteristics**

Due to the rise in Japan’s aging population, increasing numbers of elderly patients are being hospitalized in acute-phase medical institutions and are receiving highly invasive treatment. Therefore, in nursing, it has become extremely important to determine accurately the kind of medical care and nursing resources provided to patients. It has also become equally important to use management tools to deliver safe and secure nursing care to patients.

To assure the appropriate distribution of nursing resources, the findings on the visualization of the amount of nursing care based on the classification of patient characteristics can be used in the electronic health record system as a management tool.

In overseas countries such as the U.S. and Belgium, the NMDS was developed in order to clarify

nursing resources distributed according to health problems or nursing diagnoses [5]. There is an on-going study in Belgium regarding the use of NMDS in the distribution of nurses [14]. The problem, however, has been the standardization of nursing terms used in NMDS. Thus, research regarding the use of standardized nursing terms, which appears in the nursing diagnoses of the North American Nursing Diagnosis Association (NANDA); Nursing Intervention Classification: (NIC); and International Classification for Nursing Practice: (ICNP), has been conducted [15,16,17,18,19]. Also, in order to standardize nursing terms internationally, the cross mapping of nursing terms used in the SNOMED-CT (Systematized Nomenclature of Medicine-Clinical Terms) is currently being evaluated [20,21,22,23].

Concerning the standardization of terms used in Japan, there are medical institutions that have adopted the NANDA nursing terms using nursing practice records. However, the use of these nursing terms, which only the nursing staff can understand and which makes an accurate diagnosis difficult, has become problematic. Hence, the use of these nursing terms has not become widespread. Therefore, in order for NMDS to be adopted and used in Japan, nursing terms must first be standardized.

In this study accumulated nursing-care data was used secondarily and all of the nursing interventions were analyzed. As a result, by analyzing the terms used for nursing interventions in this study, we found that cross mapping is possible with the ICNP, which strives for an internationally standardized system of nursing terms.

The DRG was used as a reference for the DPC system in Japan. Then a comprehensive evaluation tool, based on Japan's own diagnosis procedure combination, was developed. However, factors concerning nursing are not reflected in the DPC system. For that reason, the standardization of nursing information has fallen behind. Yet, when the nursing care provided to patients with the same disease or treatment is evaluated quantitatively and qualitatively, it is necessary to clearly define the nursing standard that guarantees the minimum level of quality, which then becomes the standard for comparison.

In order to establish a technique for discovering parameters that affect the amount of nursing care, specific DPC codes were established. Then representative parameters discovered by apriori were evaluated and were then adapted to the decision tree to establish a generalized concept. The results showed that the parameters discovered in this study can be utilized in other institutions and a comparison of parameters is possible between institutions. By making comparisons between institutions, the patient will be assured the same standard of nursing care based on an objective index.

Also, the relationship between patient characteristics and the amount of nursing care was analyzed, using the classification of the DPC system based on the input of data on diagnoses and medical resources. Thus, the visualization of nursing care, based on factors such as the patient's ADL and age was possible.

Hence, in this study, we suggest that continued investigation will lead to the effective utilization of

limited nursing resources, the improvement of medical care security, and satisfaction for patients.

## **6. Conclusions**

In this study accumulated nursing-care data was used secondarily and the amount of nursing care was visualized using patient characteristics based on the DPC system. To improve accessibility to nursing care, a scientific nursing care standard was suggested as well.

Important issues in ensuring the quality of nursing care at acute-phase hospitals are the objective analysis of the amount of nursing care patients need and the development of a tool that allows for the proper placement of nursing staff and the precise distribution of nursing resources.

We will continue working on studies that can contribute to the further standardization of nursing care based on evidence, by performing analyses on nursing care data.

## **Limitations of the study**

Analyses were made on three DPC codes in this study. However, further analyses should be performed on other DPC codes. Moreover, this study was conducted in one medical facility, as it was the only place with a system that could extract the amount of care provided to the patients from the nursing practice record.

In the future, it will be necessary to continue to investigate the classification of patient characteristics and the amount of nursing care in collaboration with other medical facilities. Therefore, we want to continue to stress the importance of incorporating a standardized system in the HIS while using nursing information secondarily.

## **Acknowledgement**

We wish to thank the Joint Research Laboratory, Kagoshima University Graduate School of Medical and Dental Sciences, for the use of their facilities.

## **Reference**

1. Matsuda, S. [Case mix based payment and DPC from an international perspective]. *Gan To Kagaku Ryoho*2004; 31(8): 1152-1157.
2. Horiguchi, H., Yasunaga, H., Hashimoto, H., Matsuda, S. Impact of drug-eluting stents on treatment option mix for coronary artery disease in Japan. *Circulation Journal* 2010; 74(8): 1635-1643.
3. Murata, A., Matsuda, S., Kuwabara, K., Fujino, Y., Kubo, T., Fujimori, K., Horiguchi, H. Evaluation of compliance with the Tokyo Guidelines for the management of acute cholangitis based on the Japanese administrative database associated with the Diagnosis Procedure Combination system. *Journal Of Hepato-Biliary-Pancreatic Sciences* 2011; 18(1): 53-59.
4. Kadono, Y., Yasunaga, H., Horiguchi, H., Hashimoto, H., Matsuda, S., Tanaka, S., Nakamura, K. Statistics for orthopedic surgery 2006-2007: data from the Japanese Diagnosis Procedure

- Combination database. *Journal Of Orthopaedic Science* 2010; 15(2): 162-170.
5. Werley, HH., Devine, EC., Zorn, CR., Ryan, P., Westra, BL. The Nursing Minimum Data Set: Abstraction Tool for Standardized, Comparable, and Essential Data. *American Journal of Public Health* 1991; 81(4): 421-426.
  6. Park, M., Delaney, C., Maas, M., Reed, D. Using a Nursing Minimum Data Set with older patients with dementia in an acute care setting. *Journal Of Advanced Nursing* 2004; 47(3): 329-339.
  7. Evers, G., Viane, A., Sermeus, W., Simoens-De Smet, A., Delesie, L. Frequency of and indications for wholly compensatory nursing care related to internal food intake: a secondary analysis of the Belgium National Nursing Minimum Data Set. *Journal Of Advanced Nursing* 2000; 32(1): 194-201.
  8. Myny, D., Van Goubergen, D., Limere, V., Gobert, M., Verhaeghe, S., Defloor, T. Determination of standard times of nursing activities based on a Nursing Minimum Data set. *Journal of Advanced Nursing* 2010; 66(1): 92-102.
  9. Uto, Y., Kumamoto, I. Study on weighting of amount of nursing care using data on index of patient's need for nursing and system approach. *Journal Of Medical Systems* 2005; 29(2): 165-177.
  10. Uto, Y., Torigoe, C., Mukaikubo, S., Kubota, M., Muranaga, F., Kumamoto, I. Examination and Evaluation of Nursing Dependency for Admission Fee and Measurement of Nurses' Work Load for Nursing Care. *The 29th Japan Association for Medical Informatics* 2009; 429-432.
  11. Muranaga, F., Kumamoto, I., Uto, Y. Development of hospital data warehouse for cost analysis of DPC based on medical costs. *Methods Of Information In Medicine* 2007; 46(6): 679-685.
  12. Graham, W., Robert, G., Kurt, H., Giovanni, GP. *Data Mining with Rattle and R. The Art of Excavating Data for Knowledge Discovery*: Springer; 2011. Pp193-197.
  13. Lee, AH., Yau, KK. Determining the effects of patient case mix on length of hospital stay: a proportional hazards frailty model approach. *Methods Of Information In Medicine* 2001; 40(4): 288-292.
  14. Van den Heede, K., Simoens, S., Diya, L., Lesaffre, E., Vleugels, A., Sermeus, W. Increasing nurse staffing levels in Belgian cardiac surgery centres: a cost-effective patient safety intervention? *Journal of Advanced Nursing* 2010; 66(6): 1291-1296.
  15. Coenen, A., Ryan, P., Sutton, J., Devine, EC., Werley, HH., Kelber, S. Use of the nursing minimum data set to describe nursing interventions for select nursing diagnosis and related factors in an acute care setting. *Nursing Diagnosis* 1995; 6(3): 108-114.
  16. Van den Heede, K., Michiels, D. Thonon, O. Sermeus, W. Using Nursing Interventions Classification as a framework to revise the Belgian Nursing Minimum Data Set. *International Journal of Nursing Terminologies & Classifications* 2009; 20(3): 122-131.
  17. Lunney, M., Delaney, C., Duffy, M., Moorhead, S., Welton, J. Advocating for standardized nursing languages in electronic health records. *The Journal of Nursing Administration* 2005; 35(1): 1-3.
  18. Coenen, A., Weis, DM., Schank, MJ., Matheus, R. Describing parish nurse practice using the Nursing Minimum Data Set. *Public Health Nursing* 1999; 16(6): 412-416.

19. Timm, JA., Behrenbeck, JG. Implementing the Nursing Outcomes Classification in a clinical information system in a tertiary care setting. *Journal of Nursing Care Quality* 1998; 12(5): 64-72.
20. Park, HA., Lundberg, C., Coenen, A., Konicek, D. Evaluation of the content coverage of SNOMED CT representing ICNP seven-axis version 1 concepts. *Methods of Information in medicine* 2011; 50(5): 472-478.
21. Park, HA., Lundberg, C., Coenen, A., Konicek, D. Mapping ICNP Version 1 concepts to SNOMED CT. *Studies in health technology and informatics* 2010; 160(Pt 2): 1109-1013.
22. Park, HA., Lundberg, CB., Coenen, A., Konicek, DJ. Evaluation of the content coverage of SNOMED-CT to represent ICNP Version 1 catalogues. *Studies in health technology and informatics* 2009; 146: 303-307.
23. Hyun, S., Park, HA. Cross-mapping the ICNP with NANDA, HHCC, Omaha System and NIC for unified nursing language system development. *International Classification for Nursing Practice. International Council of Nurses. North American Nursing Diagnosis Association. Home Health Care Classification. Nursing Interventions Classification. International nursing review* 2002; 49(2): 99-110.