

Tillage Resistance on Tip and Straight Portion of a Rotary Blade

Koichi IWASAKI, Yoshiteru MIYABE, Sumitaka KASHIWAGI
and Jun SAKAI*

(Laboratory of Agricultural Systems Engineering)

Received for Publication September 10, 1991

Introduction

The shape of a Japanese rotary blade consists of three dimensional surfaces. Tillage which means cutting, shearing, destroying and throwing soil is done in the motion of forward movement and rotation. Considering such complicated process of tillage, for a reasonable analysis of the dynamic characteristics of tillage resistance, it is quite natural that we should separate a blade into two portions, the bending tip portion and the straight portion. The two featuring forces mentioned below are suggested⁵⁾ as,

(1) Suction force: S

As shown in Fig. 1(a), the shape of the tip portion of a rotary blade is similar to that of the moldboard plow surface. Suction force known concerning the plow could exist as a rotary blade acting in the radius direction. This force is named "Suction Force" of a rotary blade.

(2) Centripetal force: E

As shown in Fig. 1(b), the straight portion of a rotary blade has a flat surface in the moving direction, but declines against the radial direction, so it is presumed that there must be some forces that might be called "Centripetal Force" in the radial direction.

In this paper, for the purpose of elucidating these two forces, measurement of tillage resistance on each portion was carried out. Clarifying these two forces leads to an establishment of designing theory for rotary tillers and tractor mounted with them.

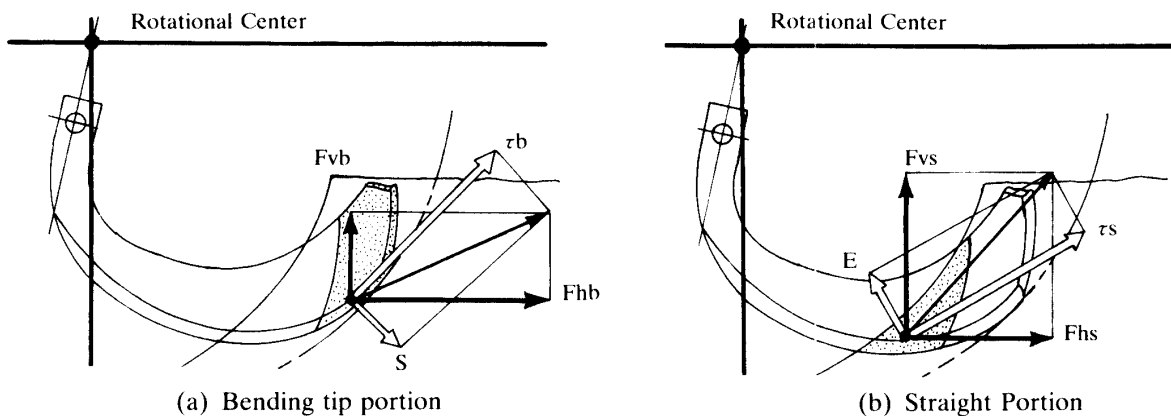

Fig. 1. Rotational resistance τ_b , τ_s , radial suction forces S and centripetal force E of a rotary blade.

* Faculty of Agriculture, Kyushu University, Fukuoka

Experimental Apparatus and Methods

The tested rotary blade, shown in Fig. 2, was designed by computer program based on designing theory for Japanese rotary blade by Sakai *et al.*²⁻⁴⁾. The tested blade was cut along the boundary between the bending tip portion and the straight portion.

The measuring apparatus¹⁾ is shown in Fig. 3. Tillage resistance was measured with gauges attached on the blade shaft. This measuring apparatus was mounted on a tractor and the specification of the tractor is shown in Table 1. Tested soil was composed of sandy clay loam and its physical properties are shown in Table 2 and was prepared in the following way,

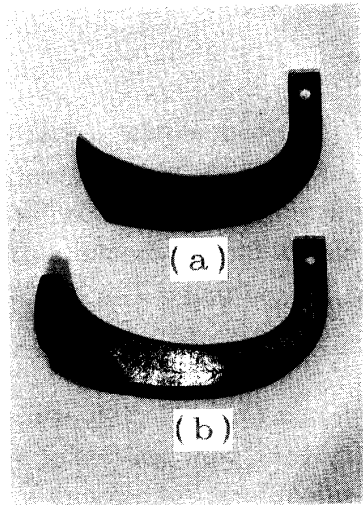

Fig. 2. Tested blade.
(a) tipless straight blade
(b) standard blade

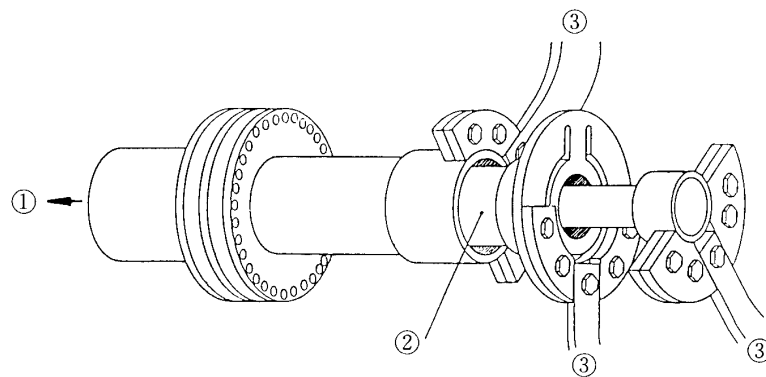

Fig. 3. Measuring apparatus.
① driving unit ② blade shaft on which strain gauges were attached ③ rotary blade

Table 1. Specification of the tractor

Type	YM1500
Engine power	15 PS
Whole length	2585 mm
Whole width	1040 mm
Wheel base	1420 mm
Front tread	840 mm
Rear tread	800 mm
Whole weight	605 kg

Table 2. Physical properties of the tested soil

Classification	Sandy clay loam
Size distribution	
Clay	21.0%
Silt	17.5%
Sand	61.5%
Plastic limit	30.1%
Liquid limit	34.7%
Plasticity index	4.6
Specific gravity	2.69

1) Soil was tilled enough and the moisture content was kept constant. 2) It was compacted by roller. Last hardness of the soil surface was 8.50 kg/cm^2 by Yamanaka hardness tester. The moisture content was 22% (d.b.). Tillage depth was 143 mm in average.

It is quite difficult to measure tillage resistance of both the bending tip portion and the straight portion independently when a rotary tiller is moving forward. In this paper, measurement was done by a stable method. The process of measurement is explained below.

A standard blade was attached to the measuring apparatus which had to till the part A, shown in Fig. 4, and then the stable tillage was done. Then the tractor was moved forward in a certain distance and a standard blade was attached to the measuring apparatus so as to till part B to attain the stable tillage. After these prearrangements, tillage measurement was carried out as follows.

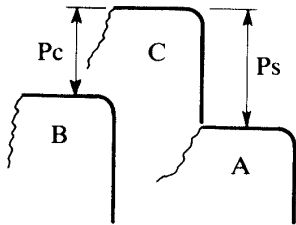

Fig. 4. Tillage pattern on soil surface.

Table 3. Combination of tillage pitch

Ps (mm)	Pc (mm)
60	30
	60
	90
90	30
	60
	90

The tractor was moved forward in a certain distance and a tipless straight blade was attached on the measuring apparatus so as to till part C. And stable tillage was carried out and tillage resistance of the straight portion was measured. Then instead of the straight blade the standard blade was attached on the measuring apparatus and stable tillage was done at the same place. In such a manner tillage resistance of the tip portion of a rotary blade was measured.

In the case of a standard blade, after the same prearrangement the standard blade was attached in the beginning, and then tillage resistance of the standard blade was measured.

Tillage pitch on the straight side is named P_s , and the one on the bending side is named P_c , and the combination of tested tillage pitches is shown in Table 3.

Results and Discussions

Samples of measured tillage resistance curves of F_h (the force in the forward direction), F_v (the force in the upward direction) and M_t (rotational torque) at $P_c=90 \text{ mm}$ and $P_s=60 \text{ mm}$ are shown in Fig. 5(a)-(d). These figures show (a) tillage resistance curve of only the straight portion, (b) tillage resistance curve of only the bending tip portion, (c) tillage resistance curve of the standard blade, and (d) composed resistance curve of the straight and the bending tip portions. A dotted line shows the resistance curve of the standard blade for reference.

Comparing the standard blade resistance curve and the composed resistance curve of the straight and the bending tip portions, the rising trend of the resistance curve, the maximum of tillage resistance and the decreasing trend of the curve showed a high similarity excepting the fact that the maximum value of F_h and M_t of composed curves were a little bigger than the standard blade curve. Because of the similarity, this method was considered to have a good reliability.

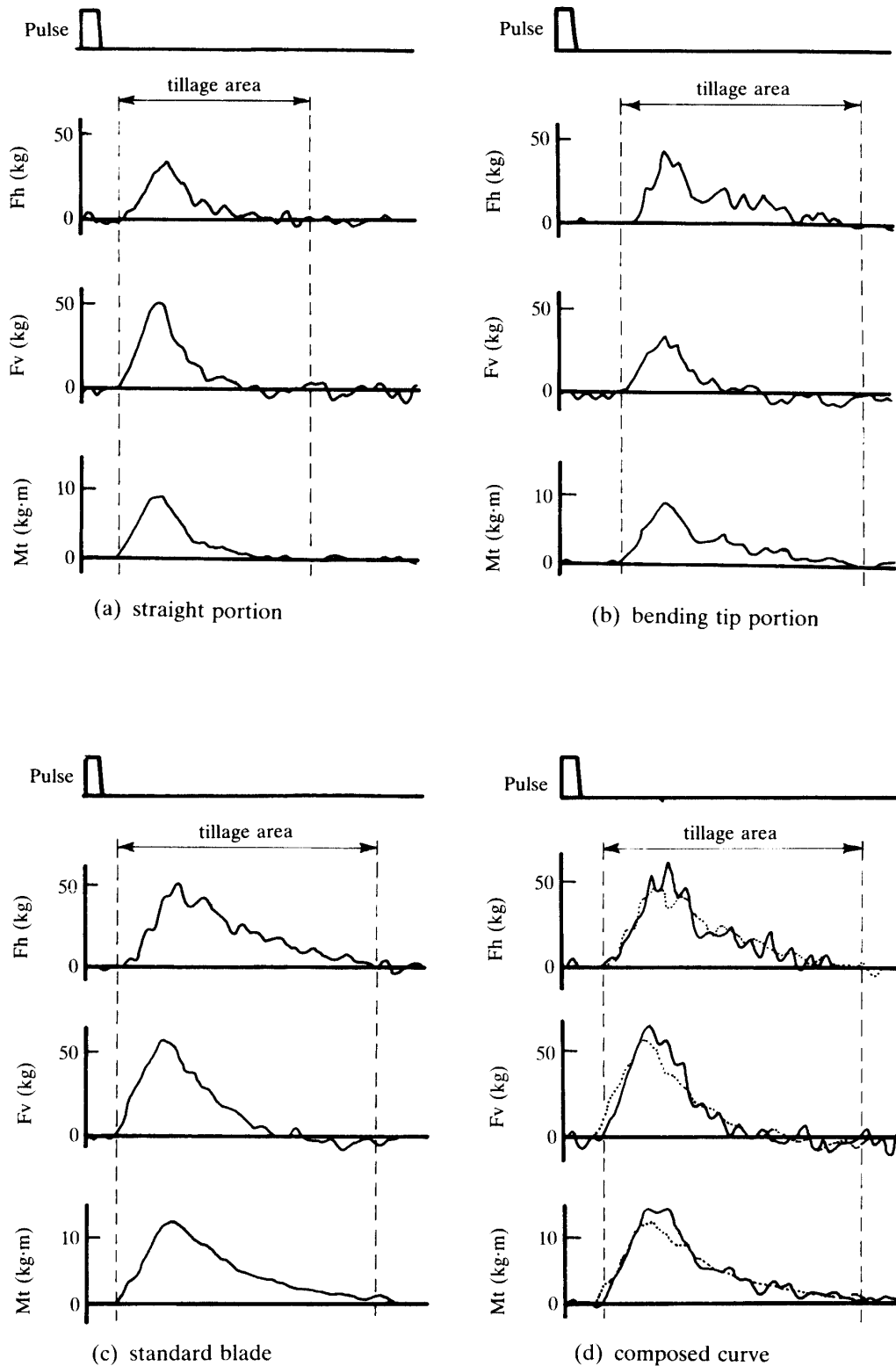

Fig. 5. Examples of measured resistance curves.
($P_c=90$ mm, $P_s=60$ mm)

1. Analysis of tillage resistance

(1) The rising point of tillage resistance

Rotational angle α of the rotary shaft from the beginning of cutting of the straight portion to that of the tip portion was calculated geometrically by the crossing point of the ground surface and the path of blade motion. In the case of $P_s=90$ mm, α was 15 deg and in the case of $P_s=60$ mm, α was 8 deg. On the contrary, measured angle of α was 16.5 deg and 9.5 deg, being quite close to the calculated values.

The rotational angle from pulse sign to the rising point of resistance was calculated to be 7 deg smaller in the case of $P_s=60$ mm than in that of $P_s=90$ mm, and the tested data showed the same average results. As for the bending tip portion, the rotational angle from pulse sign to the rising point of resistance showed constant values as calculated.

(2) The position of maximum value

The average rotational angles from the rising point of the resistance to the maximum value are shown in Table 4. In this table, concerning the bending tip portion, the revised values are also shown, which are calculated as follows. Plus 9.5 deg in the case of $P_s=60$ mm, plus 16.5 deg in the case of $P_s=90$ mm so as to compare with the straight blade resistance curve. The parenthesized values are for the purpose of comparing the position of the maximum value that were calculated plus 7 deg which is the rotational angle disparity from the rising point in the case of $P_s=60$ mm and in that of $P_s=90$ mm.

Table 4. Average rotational angles from the rising point to the maximum value of resistance (deg)

	P_s (mm)	Straight portion	Tip portion	Revised value	Standard blade
Fh	60	19.0 (26.0)	20.0	29.5	29.5 (36.5)
	90	32.5	21.0	37.5	36.0
Fv	60	16.0 (23.0)	16.5	26.0	24.0 (31.0)
	90	24.0	19.5	36.0	25.0
Mt	60	16.0 (23.0)	20.5	30.0	24.0 (31.0)
	90	25.5	20.5	37.0	32.5

In comparing the blade position of the maximum value of each resistance, when $P_s=60$ mm and 90 mm, Fh, Fv, Mt showed similar value and independent of P_s .

As to Fh, the position of the maximum value of the bending tip portion and the standard blade was about the same. As to Fv and Mt, at the middle point of the maximum value of the straight blade and the bending tip portion, the resistance of the standard blade showed the maximum value. The tillage resistance showed the maximum value around the position where the straight blade comes down to the ground surface. These results differ from the results by Shibata *et al.*⁶⁾ and the reason was considered as follows.

Shibata *et al.*'s results were obtained with the silt loam and these results were obtained with sandy loam. Moreover the process of deformation against blade penetration was different. In the case of sandy soil, the crack occurs earlier with the penetration of rotary blade and when the

blade comes into soil surface the resistance rises rapidly and at the moment of first crack the maximum resistance occurs. After that, tillage resistance rapidly decreases and from the moment when the bending tip portion comes into soil, the resistance decreases gradually, and at last it comes to zero when the blade goes out of the soil.

2. Value of the tillage resistance

The relations of average values of Fh, Fv and Mt versus Pc and Ps are shown in Fig. 6 (a)-(d). Fh and Mt increased linearly with the increase of Pc. In general, the order of resistance value were the standard blade, the bending tip portion and the straight portion. With the increase of Pc, Fv increased and the increasing ratio was bigger in the case of having a range of Pc=60 mm to 90 mm than from Pc=30 mm to 60 mm. In general, the order of resistance value was fixed as in the following, namely the standard blade, the straight portion and the bending tip portion, and the value on the straight blade is relatively bigger in the case of Fv than in that of Fh.

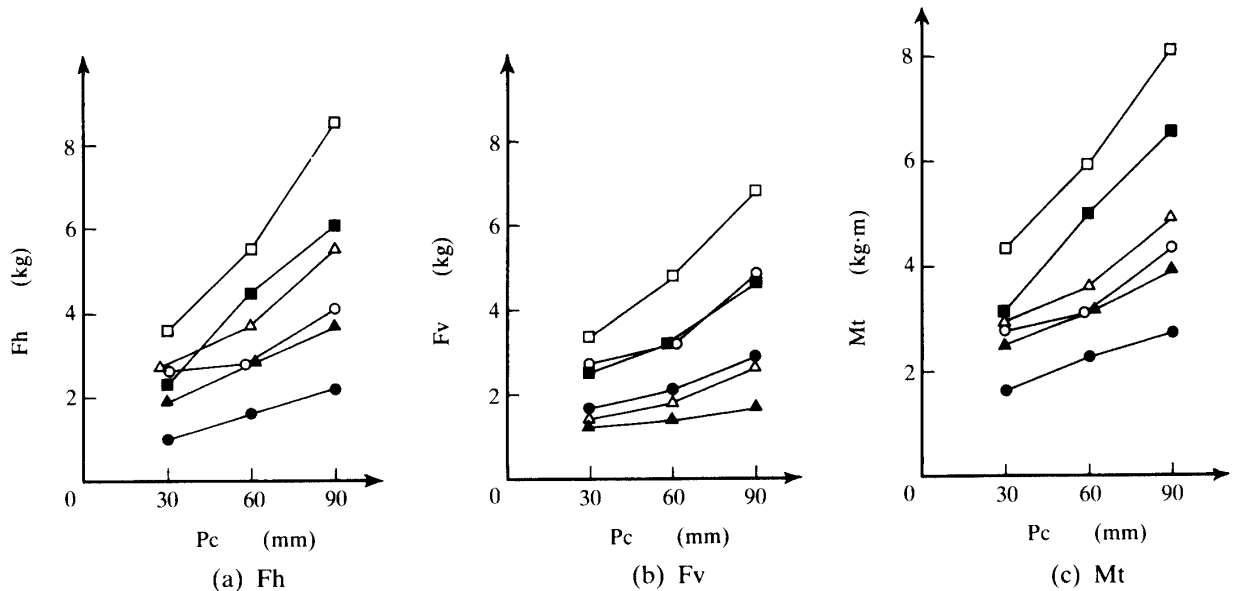

Fig. 6. Average values of Fh, Fv and Mt versus Pc and Ps.

	Ps=60 mm	Ps=90 mm
straight portion	●	○
bending tip portion	▲	△
standard blade	■	□

3. The direction and the position of tillage resistance

(1) Direction of acting line of tillage resistance

The angle θ of tillage resistance from the direction of the movement of a tractor is calculated as,

$$\theta = \tan^{-1} (Fv/Fh).$$

The relations of Pc, Ps versus θ are shown in Fig. 7(a). θ tends to be rather smaller when Pc becomes bigger but has no relation against Ps and showed constant value. The average values are as follows.

- standard blade : 41.4 deg
- straight portion : 51.2 deg

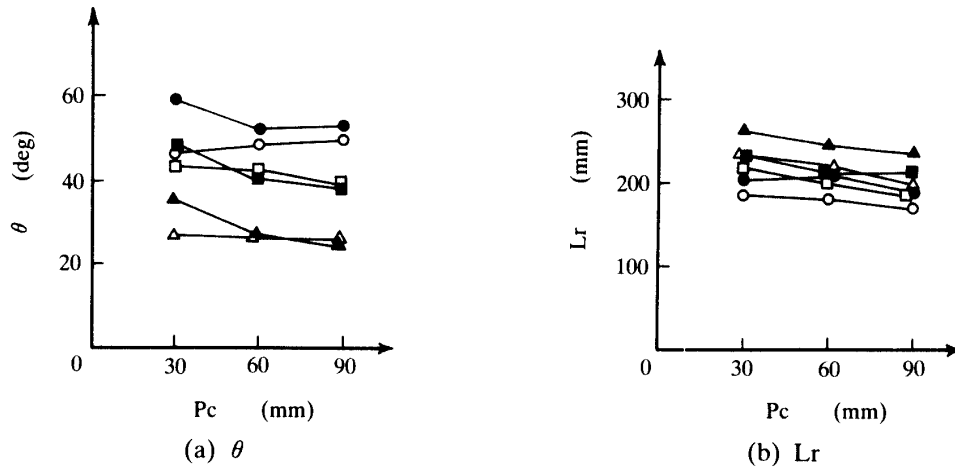

Fig. 7. Average values of θ and L_r versus P_c and P_s .

	$P_s=60\text{ mm}$	$P_s=90\text{ mm}$
straight portion	●	○
bending tip portion	▲	△
standard blade	■	□

tip portion : 27.6 deg

(2) Position of the acting line

Position of tillage resistance acting line L_r is

$$L_r = Mt / (F_h^2 + F_v^2)^{1/2}$$

The relations of P_c , P_s versus L_r are shown in Fig. 7(b). L_r showed bigger value in the order of the straight portion, the standard blade and the tip portion in each P_s . When P_c increases, L_r showed a little increase, and L_r obviously showed smaller value in the case of $P_s=60\text{ mm}$ than $P_s=90\text{ mm}$. Although when P_s becomes small the quantity of the tilled soil reduces, the position of the line of action goes far from the center.

When $P_s=75\text{ mm}$ and $P_c=60\text{ mm}$ the average values of L_r were,

standard blade	: 210.5 mm
straight portion	: 190.1 mm
tip portion	: 233.7 mm

4. Distribution of tillage resistance on the tip and the straight portion

Tillage resistance on the straight and the tip portions are defined as W_s and W_c independently, and that of the standard blade was W_z , then the following equation is obtained in accordance with the testing results.

$$W_z = W_s + W_c$$

Distribution of tillage resistance on the straight portion is defined as $Z_s (=W_s/W_z)$, and that of the tip portion as $Z_c (=W_c/W_z)$, and in that case

$$Z_s + Z_c = 1.$$

So in discussing about the distribution of tillage resistance, analyzing one of them is enough, and in this paper Z_c is discussed. The distribution of each F_h , F_v , M_t is expressed with subscript of h , v , t .

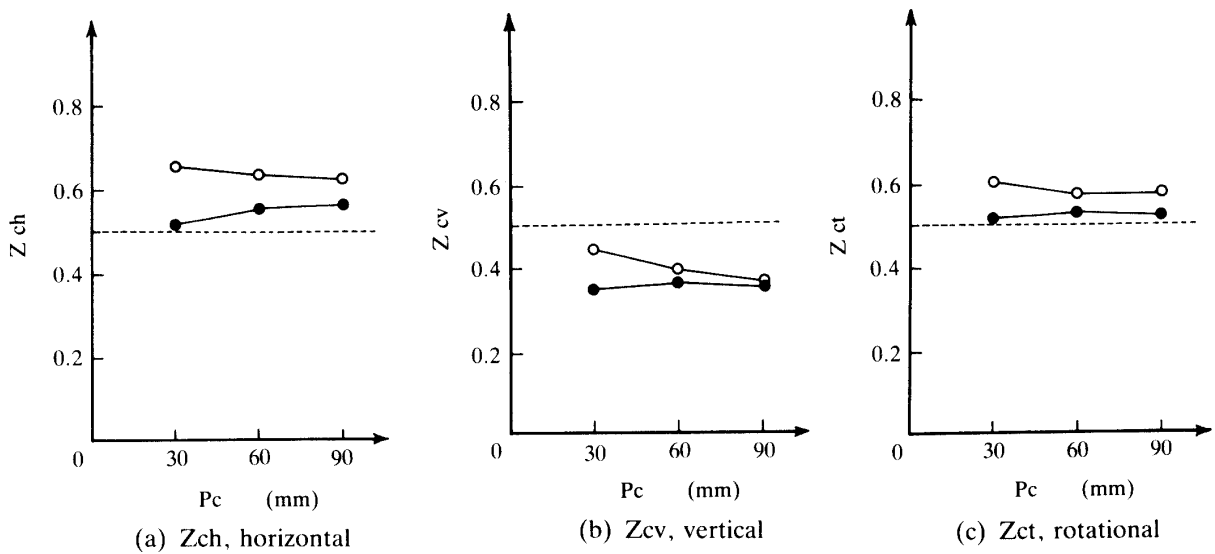

Fig. 8. Tillage resistance distribution on bending tip portion.

○: Ps=60 mm, ●: Ps=90 mm

The relations of Pc, Ps versus Z_{ch} are shown in Fig. 8(a). With the increase of Pc from 30 mm to 90 mm, Z_{ch} increases a little in case when Ps=90 mm, but decreases a little in case when Ps=60 mm, though the ratio is so small and the value is considered to be nearly constant. The average value was 0.64 at Ps=90 mm and 0.55 at Ps=60 mm and around 60% of the whole resistance was on the tip portion and 40% of it on the straight portion, in average.

The relations of Pc, Ps versus Z_{cv} are shown in Fig. 8(b). With the increase of Pc from 60 mm to 90 mm, Z_{cv} decreases a little at Ps=60 mm but Z_{cv} is nearly constant at Ps=90 mm. Average value of Z_{cv} is 0.41 at Ps=60 mm, 0.36 at Ps=90 mm, and around 40% of the standard blade resistance is on the tip portion and 60% is on the straight portion in average.

The relations of Pc, Ps versus Z_{ct} are shown in Fig. 8(c). Z_{ct} showed its constancy at any value of Pc and average value was 0.59 at Ps=60 mm and 0.53 at Ps=90 mm. This result was caused because F_h and F_v were distributed around half on tip and straight portion but the distances from the rotational center to each resistance were different.

Summary

Japanese rotary blade has a three dimensional surface and for the purpose of analyzing the mechanism of the tillage resistance, a better way is to analyze it by separating it into two portions: the bending tip portion and the straight portion. In this paper, tillage resistance of two portions of a blade were measured. The obtained results were indicated as follows.

(1) As all the transition portion between the straight and the bending portions go in to the soil, the tillage resistance shows the maximum value.

(2) The average direction (angle from the horizontal direction) and the position (the minimum length from the center of rotation to the acting line of the resistance) were: as to the straight portion 51.2 deg and 190.3 mm, as to the tip portion 27.6 deg and 233.7 mm, as to the standard blade 41.4 deg and 210.5 mm, respectively.

(3) Distributions of tillage resistance on the tip and the straight portions were: as to the straight portion F_h 40%, F_v 60% and M_t 47%, as to the tip portion F_h 60%, F_v 40% and M_t

53%. The obtained results were slightly different from the results presented in the previous works. This is because the test soil in this experiment was sandy clay loam but that of the earlier work was clay loam, and therefore the soil failure-processes of both the experiments were different.

Further experiments in various tillage conditions are expected and the total results through these experiments may lead to the fixing of a reasonable designing-theory concerning the rotary tilling equipments.

References

- 1) Hashiguchi, K., Sakai, J., Yamanaka, S. and Iwasaki, K.: Development of the Measuring Device for Six-Components of Rotary Tillage Resistance and Analysis of Torque Waves. *J. Soc. Agr. Machinery, Japan*, **47**(3), 311–320 (1985) (in Japanese with English Summary)
- 2) Lam, V. H. and Sakai, J.: Studies on the Cultivating Characteristics of the Knife-Edged Curve of Japanese Rotary Blades. *J. Soc. Agr. Machinery, Japan*, **44**(4), 611–615 (1983) (in Japanese with English Summary)
- 3) Sakai, J., Shibata, Y. and Taguchi, T.: Design Theory of Edge-Curves for Rotary Blades of Tractors. *J. Soc. Agr. Machinery, Japan*, **38**(2), 183–190 (1976) (in Japanese with English Summary)
- 4) Sakai, J. and Shibata, Y.: Design Theories on Scoop-Surfaces of Rotary Blades for Tractors. *J. Soc. Agr. Machinery, Japan*, **39**(1), 11–20 (1977) (in Japanese with English Summary)
- 5) Sakai, J., Lam, V. H., Iwasaki, K. and Shibata, Y.: Tillage Resistance Characteristics of Japanese Rotary Blades. *J. Soc. Agr. Machinery, Japan*, **46**(1), 593–598 (1984) (in Japanese with English Summary)
- 6) Shibata, Y. and Sakai, J.: Study on Rotary Tillage Resistances of a Japanese C-shaped Blade. *J. Soc. Agr. Machinery, Japan*, **39**(4), 447–457 (1978) (in Japanese with English Summary)